



# Poolregelung BADU®Eco Logic

Installation and operating instruction



**Read carefully before installation, commissioning and operation**

# Table of content

	page	page
<b>Safety instructions</b>		19
<b>A.1. EC declaration of conformity</b>	<b>3</b>	19
<b>A.2. General instructions</b>	<b>3</b>	19
<b>A.3. Explanation of symbols</b>	<b>3</b>	19
<b>A.4. Changes to the unit</b>	<b>4</b>	
<b>A.5. Warranty and liability</b>	<b>4</b>	
<b>Description of controller</b>		
<b>B.1. Specifications</b>	<b>5</b>	
<b>B.3. About the controller</b>	<b>6</b>	
<b>B.4. Scope of supply</b>	<b>6</b>	
<b>B.5. Disposal and pollutants</b>	<b>6</b>	
<b>B.6. Hydraulic variants</b>	<b>7</b>	
<b>Installation</b>		
<b>C.1. Wall installation</b>	<b>8</b>	
<b>C.2. Electrical connection</b>	<b>9</b>	
D. Klemmplan für elektrischen Anschluss	11	
<b>Operation</b>		
<b>E.1. Display and input</b>	<b>12</b>	
<b>E.2. Commissioning help</b>	<b>13</b>	
<b>E.3. Free commissioning</b>	<b>13</b>	
<b>E.4. Menu sequence and menu structure</b>	<b>14</b>	
<b>2. Statistics</b>	<b>15</b>	
2.1. Operating hours	15	
2.2. --	15	
2.3. --	15	
2.4. Graphic overview	15	
2.5. Message log	15	
2.6. Reset/clear	15	
<b>3. Display mode</b>	<b>16</b>	
3.1. Schematic	16	
3.2. Overview	16	
3.3. Alternating	16	
3.4. Sleep mode	16	
<b>4. Operating mode</b>	<b>17</b>	
4.1. Automatic	17	
4.2. Manual	17	
4.3. Off	17	
<b>5. Settings</b>	<b>18</b>	
5.1. --	18	
5.2. --	18	
5.3. Filter pump	18	
5.3.1. Min. hourly filtering time	18	
5.3.3. Enable filter pump	18	
5.3.4. Clear rinse time	18	
5.3.5. Clear rinse stage	18	
5.3.6. Clear rinse level V1	19	
5.3.8. Daily filtering time	19	
5.4. Relay 1	19	
5.4.1. Function	19	
5.4.2. --		20
5.4.3. --		20
5.4.4. Times		20
<b>6. Protective functions</b>	<b>20</b>	
6.1. Seizing protection		20
6.2. --		20
6.3. --		20
<b>7. Special functions</b>	<b>21</b>	
7.1. --		21
7.2. Time and date		21
7.3. --		21
7.4. Commissioning		21
7.5. Factory settings		21
7.6. --		21
7.7. --		22
7.8. Daylight saving time		22
7.9. Signal mode		22
7.10. 0-10 V Signal		22
7.10.1. Signal at level 1		22
7.10.2. Signal at level 2		22
7.10.3. Signal at level 3		22
<b>8. Menu lock</b>	<b>23</b>	
<b>9. Service data</b>	<b>24</b>	
<b>10. Language</b>	<b>24</b>	
<b>Z.1. Malfunctions with error messages</b>	<b>25</b>	
<b>Z.2. Replacing the fuse</b>	<b>26</b>	
<b>Z.3. Maintenance</b>	<b>26</b>	
<hr/>		
<b>Connection example for BADU Eco pumps 28</b>		

# Safety instructions

## A.1. EC declaration of conformity

By affixing the CE mark to the unit the manufacturer declares that the BADU®Eco Logic conforms to the following relevant safety regulations:

EC low voltage directive 2006/95/EC

EC electromagnetic compatibility directive 2004/108/EC.

Conformity has been verified and the corresponding documentation and the EC declaration of conformity are kept on file by the manufacturer.

## A.2. General instructions

These installation and operating instructions contain basic instructions and important information regarding safety, installation, commissioning, maintenance and the optimal use of the unit. Therefore these instructions must be read completely and understood by the installation technician/specialist and by the system user before installation, commissioning and operation of the unit.

This device is an automatic, electronic controller for similar uses. Only install the controller in a dry room and under ambient conditions listed in “B.1. Specifications” on page 5.

The valid accident prevention regulations, the applicable standards and regulations and the installation and operating instructions of the additional system components must also be observed. The controller does not under any circumstances replace any safety devices which are to be provided by the customer!

Installation, electrical connection, commissioning and maintenance of the unit may only be carried out by specialists who have the appropriate training.

For the user: Make sure that the specialist gives you detailed information on the function and operation of the controller. Always keep these instructions in the vicinity of the controller.

## A.3. Explanation of symbols



Failure to observe these instructions can result in danger to life from electric voltage.



Failure to observe these instructions can result in serious damage to health such as scalding or even life-threatening injuries.



Failure to observe these instructions can result in destruction of the unit or the system or damage to the environment.



Information which is especially important for the function and optimal use of the unit and the system.

# Safety instructions

## A.4. Changes to the unit



Changes to the unit can compromise the safety and function of the unit or the entire system.

- Changes, additions to or conversion of the unit are not permitted without written authorisation from the manufacturer
- It is likewise forbidden to install additional components that have not been tested together with the unit
- If it becomes clear that safe operation of the unit is no longer possible, for example because of damage to the housing, turn the controller off immediately
- Any parts of the unit or accessories that are not in perfect condition must be replaced immediately
- Use only original spare parts and accessories from the manufacturer
- Markings made on the unit at the factory must not be altered, removed or made illegible
- Only the settings described in these instructions may be used on the controller

## A.5. Warranty and liability

The controller has been manufactured and tested with regard to high quality and safety requirements. The unit is subject to the statutory guarantee period of two years from the date of sale.

The warranty and liability shall not include, however, any injury to persons or material damage that is attributable to one or more of the following causes:

- Failure to observe these installation and operating instructions
- Improper installation, commissioning, maintenance and operation
- Improper repairs
- Unauthorised structural changes to the unit
- Installation of additional components that have not been tested together with the unit
- Any damage resulting from continued use of the unit despite an obvious fault
- Failure to use original spare parts and accessories
- Use of the device for anything other than its intended purpose
- Operation above or below the limit values listed in the specifications
- Force majeure

# Description of controller

## B.1. Specifications

### Electrical specifications:

Mains voltage	230 VAC +/-10 %
Mains frequency	50 - 60 Hz
Power consumption	1,5 W - 2,3 W
Internal fuse	4A slow blow 250 V
Protection category	IP40/IP 44 (only with the supplied gasket set)
Protection class	II
Overvoltage category	II
Degree of pollution category	II

mechanical relay 4 A maximum AC3	2 (R2-R3)
PT1000 sensor input measuring range -40 °C to 300 °C	3

\* Note for 3 ~ and 1 ~ pumps, see below

### Permissible cable length of sensors and appliances:

Other PT1000 sensors	< 10 m
Electronic relay	< 3 m
Mechanical relay	< 10 m

**Real Time Clock** RTC with 24 hour power reserve

### Permissible ambient conditions:

Ambient temperature	
for controller operation	0 °C - 40 °C
for transport/storage	0 °C - 60 °C
Air humidity	
for controller operation	max. 85 % rel. humidity at 25 °C
for transport/storage	no moisture condensation permitted

### Other specifications and dimensions

Housing design	2 part, ABS plastic
Installation methods	Wall installation, optional panel
Overall dimensions	163 mm x 110 mm x 52 mm
Cut out installation dimensions	157 mm x 106 mm x 31 mm
Display	Fully graphical display, 128 x 64 dots
Light diode	Multicolor red/green
Operation	4 entry keys

### \* note:

3 ~: You can also switch 3 ~ pumps with the control. Please use one of the additional switch boxes for this according to the current intensity 2716600920..923. (Engine protection and contactor and comfortable clamping of the accessories and a 2 meter multi-pole cable are contained in the switch box).

1 ~: You can also switch 1 ~ pumps of higher current intensity with the control. Use the additional switch boxes 2716600924. (A contactor and comfortable clamping of the accessories and a 2 meter multi-pole cable are contained in the switch box).

Other additional boxes are available: please inquire.

# Description of controller

## B.3. About the controller

The BADU®Eco Logic pool controller facilitates efficient use and function control of your solar or heating system with your swimming pool. The device is impressive most of all for its functionality and simple, almost self-explanatory operation. For each step in the input process the individual entry keys are assigned to appropriate functions and explained. The controller menu contains headwords for the measured values and settings as well as help texts or clearly-structured graphics.

The BADU®Eco Logic can be used as a simple system illustrated and explained under “B.6. Hydraulic variants” on page 7.

Important characteristics of the BADU®Eco Logic:

- Depiction of graphics and texts in an illuminated display
- Simple viewing of the current measurement values
- Analysis and monitoring of the system by means of statistical graphics, etc.
- Extensive menu settings with explanations
- Menu block activation to prevent unintentional setting changes
- Resetting to factory settings

## B.4. Scope of supply

BADU®Eco Logic pool controller

- 3 pcs. 3.5 x 35 mm screws and 3 pcs. 6 mm plugs for wall installation
- 6 strain relief clips with 12 screws, replacement fuse 1x T 4 A/250 V
- BADU®Eco Logic installation and operating instructions

Optionally contained depending on design/order:

-

Additionally available:

- PT1000 temperatur sensors, immersion sleeves, overvoltage protection
- A wide range of additional functions via additional circuit boards

## B.5. Disposal and pollutants

The unit conforms to the European RoHS directive 2011/65/EU for the restriction of the use of certain hazardous substances in electronic equipment.



The unit must not under any circumstances be disposed of with ordinary household refuse. Dispose of the unit only at appropriate collection points.

# Description of controller

## B.6. Hydraulic variants



The following illustration should be viewed only as schematic diagrams showing the respective hydraulic system and do not claim to be complete. The controller does not replace safety devices under any circumstances. Depending on the specific application, additional system components and safety components may be required, such as check valves, non-return valves, safety temperature limiters, scalding protectors etc. and must therefore be provided.

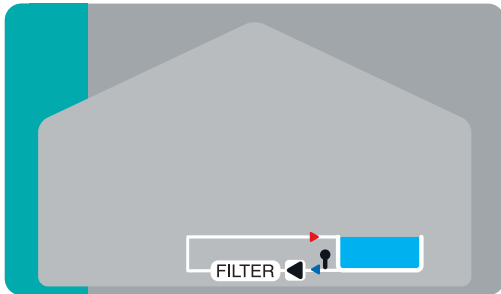

Filter pump control

# Installation

## C.1. Wall installation



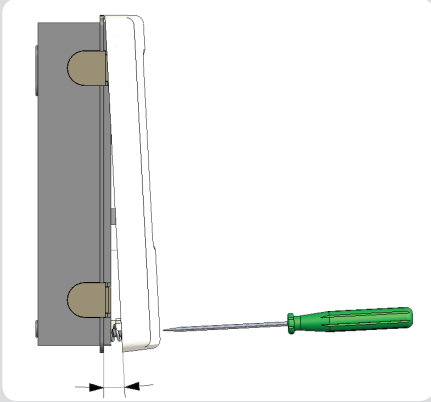

Install the controller in dry areas only and under the ambient conditions described under "B.1. Specifications". Follow the instructions below:

### C.1.1.



1. Unscrew cover completely
2. Carefully pull upper part of housing from lower part. Terminal clamps are released during this process.
3. Set upper part of housing aside, being sure not to touch the electric when doing so.
4. Hold the lower part of the housing up to the selected position and mark the 3 mounting holes. Make sure that the wall surface is as even as possible so that the housing does not become distorted when it is screwed on.

### C.1.2.

 3 x 3,5 x 30  
 3 x Ø 6

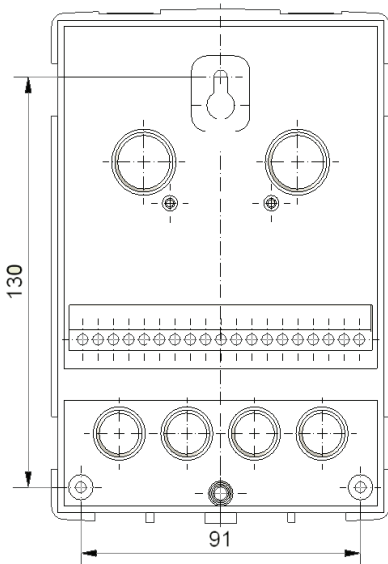

5. Using a drill and size 6 bit, drill 3 holes at the points marked on the wall and push in the dowels.
6. Insert the upper screw and screw it in slightly.
7. Fit the upper part of the housing and insert the other two screws.
8. Align the housing and tighten the three screws.

# Installation

## C.2. Electrical connection



Before working on the unit, switch off the power supply and secure it from being switched on again! Check for the absence of power! Electrical connections may only be made by a specialist and in compliance with the applicable regulations. Do not use the controller if the housing shows visible damage, for example cracks.



Low-voltage cables such as sensor cables must be routed separately from the mains voltage cables. Feed sensor cables into the left-hand side of the unit only and mains voltage cables into the right-hand side only.



The customer must provide an all-pole disconnecting device in the power supply of the controller e.g. a heating emergency switch.



The cables being connected to the unit must not be stripped by more than 55 mm and the cable jacket must reach into the housing to the other side of the strain relief.

Follow the scope of protection according to the German Institut for Standardizations VDE 0100-702 for the installation of the controller (distance to the scope of protection 0 and 1).



Danger of electric shock due to improper connection!

- Observe VDE and EVU regulations of the energy supply company.
- Install pumps and swimming pools and their scope of protection according to the German Institut for Standardization VDE 0100-702.
- Install a disconnecting device for the interruption of the power supply with min 3 mm of contact per pole.



Danger of electric shock due to voltage on the housing!

- A correctly configured motor overload switch must be installed. While doing so, observe the values on the name plate.
- Protect the power supply with a differential switch, nominal residual current  $I_{\Delta N} \leq 30 \text{ mA}$ .
- Only use suitable cables according to regional regulations.
- Adapt the minimum section of the pipe to the motor capacity and the performance range.
- Provide an emergency stop switch according to DIN EN 809 where dangerous situations could arise. The operator should make the decision based on this standard.

# Installation

## C.2.1.

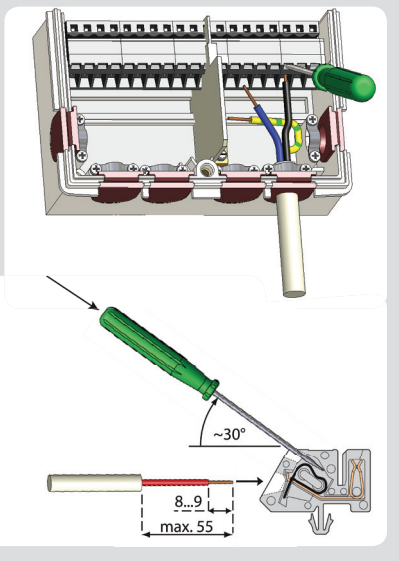

1. Open controller casing (“C.1. Wall installation” on page 8).
2. Strip cables by max. 55 mm, insert it, fit the strain relief devices, strip the last 8-9 mm of the wires (Fig. C.2.1.).
3. Open the terminals using a suitable screwdriver (Fig. C.2.1.) and make electrical connections on the controller.
4. Refit terminal connection cover and fasten screw.
5. Switch on mains voltage and place controller in operation.

# Installation

## D. Klemmplan für elektrischen Anschluss

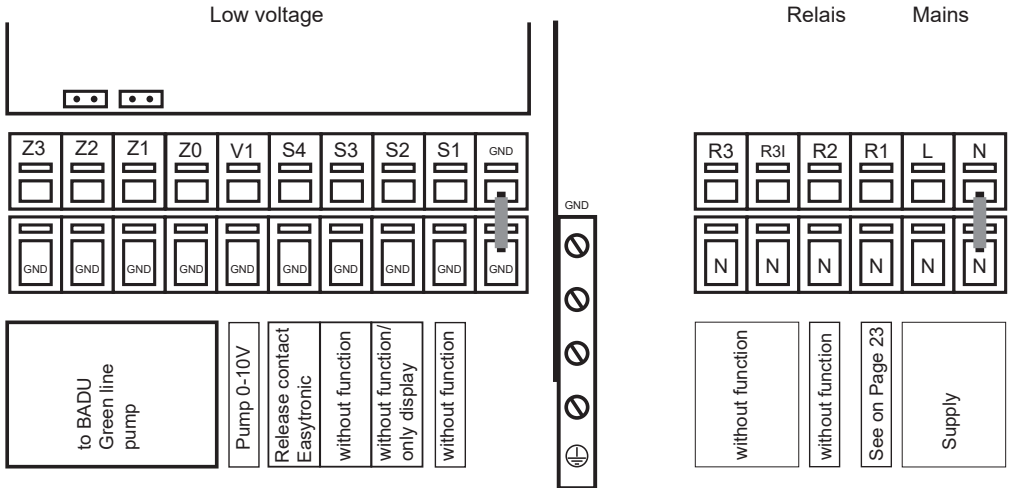

max. 12 V

### Low voltage max. 12 VAC/DC

Terminal	Connection for
S1 (2x)	without function
S2 (2x)	without function / Option: Temp.-sensor only display
S3 (2x)	without function
S4 (2x)	Release contact for Easytronic **
V1	0-10 V output for filter pump (via frequency converter) ***
Z0	Pump off
Z1	Pump level 1
Z2	Pump level 2
Z3	Pump level 3

\*\* (Insert a bridge here if not needed)

\*\*\* (Speed control for pump)



Netzseite  
230 VAC

### Mains voltage 230 VAC 50 - 60 Hz

Terminal:	Connection for:
N	Mains neutral conductor N
L	Mains phase conductor L
R1	Function see page 23
R2	without function
R3I	without function
R3	without function

The PE protective conductor must be connected to the PE metal terminal block!

# Operation

## E.1. Display and input

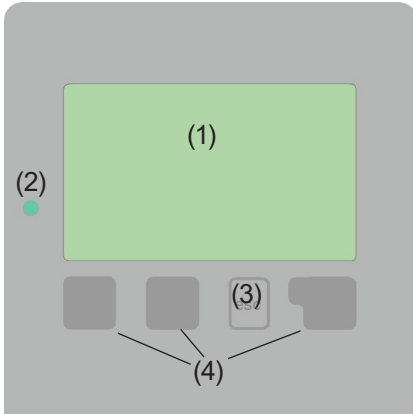

Examples of display symbols:



Pump (rotates in operation)



Pool



Warning/error message



New infos

The display (1), with its extensive text and graphics mode, is almost self-explanatory, allowing easy operation of the controller.

Inputs are made with 4 buttons (3+4), which have different functions depending on the context. The “esc” key (3) is always used to cancel or exit a menu.

If applicable there will be a request for confirmation as to whether the changes which have been made should be saved.

The function of each of the other three keys (4) is shown in the display line directly above the keys; the right-hand key generally has a confirmation and selection function.

The LED (2) lights up when a solar request is active (Ball value on/off) Other features of the LED are described in chapter Z.1.

Examples of key functions:

+/-	= enlarge/shrink values
▼/▲	= scroll down/up menu
yes/no	= approve/cancel
info	= additional information
back	= to previous screen
ok	= confirm selection
confirm	= confirm setting

# Commission

## E.2. Commissioning help



The first time the controller is turned on and after the language and time are set, a query appears as to whether you want to parameterise the controller using the commissioning help or not. The commissioning help can also be terminated or called up again at any time in the special functions menu. The commissioning help guides you through the necessary basic settings in the correct order, and provides brief descriptions of each parameter in the

display. Pressing the “esc” key takes you back to the previous value so you can look at the selected setting again or adjust it if desired. Pressing the “esc” key more than once takes you back step by step to the selection mode, thus cancelling the commissioning help. Finally, the menu “4.2. Manual” on page 18 should be used to test the switch outputs with the consumers connected and to check the sensor values for plausibility. Then the automatic mode can be switched on. Automatikbetrieb einzuschalten.



Observe the explanations for the individual parameters on the following pages and check whether further settings are necessary for your application.

## E.3. Free commissioning

If you decide not to use the commissioning help, you should make the necessary settings in the following sequence:

- Menu 10. Language
- Menu 7.2. Time and date
- Menu 5. Settings, all values
- Menu 6. Protective functions, if necessary
- Menu 7. Special functions, if necessary

Finally, the menu “4.2. Manual” on page 18 should be used to test the switch outputs with the consumers connected and to check the sensor values for plausibility. Then the automatic mode can be switched on.



Observe the explanations for the individual parameters on the following pages and check whether further settings are necessary for your application.

# Operation

## E.4. Menu sequence and menu structure

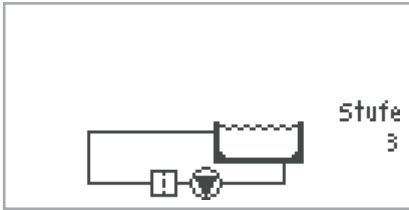

The graphics or overview mode appears when no key has been pressed for 2 minutes or when the main menu is exited by pressing the “esc” key.

Pressing a key in the graphics or overview mode will lead directly to the main menu. Here the following menus are available:

2. Statistics

Function control of the system with operating hours etc.

3. Display mode

Select graphics mode or overview mode

4. Operation mode

Automatic mode, manual mode or switch unit off

5. Settings

Set parameters needed for normal operation

6. Protective functions

Solar and frost protection, anti-seizing protection etc.

7. Special functions

Clock, factory settings, etc.

8. Menu lock

Against unintentional setting changes at critical points

9. Service values

For diagnosis in the event of an error

10. Language

Language selection

# Statistics

## 2. Statistics



The menu “2. Statistics” is used for function control and long-term monitoring of the system.

The menu is closed by pressing the “esc” key or selecting “Exit statistics”.



For analysis of the system data it is essential for the time to be set accurately on the controller. Please note that the clock only has a battery reserve for 24 hours and must therefore be reset afterwards. Improper operation or an incorrect time may result in data being deleted, recorded incorrectly or overwritten.

The manufacturer accepts no liability for the recorded data!

### 2.1. Operating hours

Display of operating hours of the pump connected to the controller; various time ranges (day-year) are available.

2.2. --

2.3. --

### 2.4. Graphic overview

This provides a clearly organised display of the above mentioned data as a bar graph. Various time ranges are available for comparison. The two left-hand keys can be used to scroll through the data.

### 2.5. Message log

Displays the last 20 events occurring in the system with indication of date and time.

### 2.6. Reset/clear

Resetting and deleting the individual analyses. The function “All statistics” clears all analyses but not the error messages.

# Display mode

## 3. Display mode

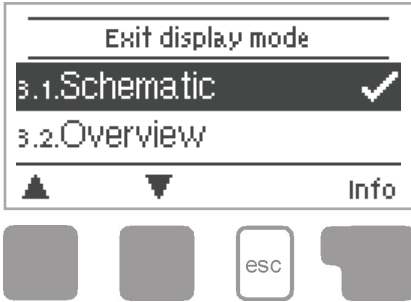

The menu “3. Display mode” is used to define the controller’s display for normal operation.

This display appears whenever two minutes go by without any key being pressed. The main menu appears again when a key is pressed.

The menu is closed by pressing the “esc” key or selecting “Exit display mode”.

### 3.1. Schematic

In graphics mode, the selected hydraulic systems are depicted with operating states of the connected consumers.

### 3.2. Overview

In overview mode, the operating states of the connected consumers are depicted in text form.

### 3.3. Alternating

In alternating mode the schematic mode and then the overview mode are active for 5 seconds at a time.

### 3.4. Sleep mode

When active, the display’s backlight is switched off after 2 minutes of inactivity.



If an error message is waiting, the backlight is not switched off.

# Operating mode

## 4. Operating mode

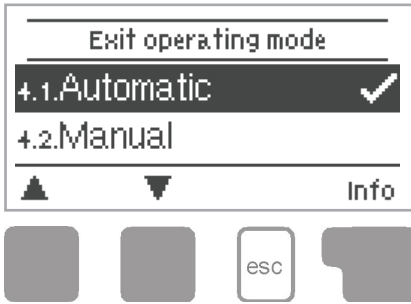

In the menu “4. Operating mode” the controller can either be placed in automatic mode, switched off or placed in a manual operating mode.

The menu is closed by pressing the “esc” key or selecting “Exit operating mode”.

### 4.1. Automatic

Automatic mode is the normal operating mode of the controller. Only automatic mode provides proper controller function taking into account the parameters that have been set! After an interruption of the mains voltage the controller automatically returns to the last operating mode selected!

### 4.2. Manual

The relay and thus the connected consumer are switched on and off, with no regard to the parameters which have been set, by pressing a key.



When the operating mode “Manual” is activated, the selected parameters are no longer considered. There is a danger of scalding or serious damage to the system. The operating mode “Manual” may only be used by specialists for brief function tests or during commissioning!

### 4.3. Off



When the operating mode “Off” is activated, all controller functions are switched off.

# Settings

## 5. Settings

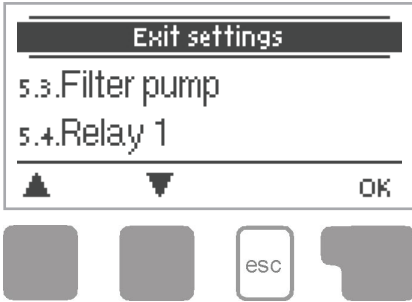

The necessary basic settings required for the control function are made in the menu "5. Settings".



This does not under any circumstances replace the safety facilities to be provided by the customer!

The menu is closed by pressing the "esc" key or selecting "Exit settings".

### 5.3. Filter pump

#### Filter pump run time

The BADU@Eco Logic controls the filtering time of the pump in which the filtering times for the minimum hourly and daily filtering are taken into consideration.

##### 5.3.1. Min. hourly filtering time

This menu is used to set the hourly filtering time.

The pump is switched on at the end of the hour for the set time.

*Setting range: off, 1 min. - 60 min. / Default: off*

##### 5.3.2. --

##### 5.3.3. Enable filter pump

In this menu the setting for enabling the filter pump via the sensor input S4 can be made. In addition the clear rinse time and the clear rinse level can also be set for Easytronic.

*Setting range: simple, Easytronic/Default: simple*

##### 5.3.4. Clear rinse time

The filter pump will run for the time set here after each release to rinse the system.

*Setting range: 0 - 30 Min/Default: 5 Min*

##### 5.3.5. Clear rinse stage

Filter pump stage during clear rinse time.

*Setting range: 1 - 3/Default: 2*

# Settings

## Filter pump

### 5.3.6. Clear rinse level V1

Level for a variable speed pump connection at V1.

*Setting range: 1 - 100 %/Default: 50 %*

### 5.3.7.--

### 5.3.8.Daily filtering time

This menu is used to set the min. daily filtering time. This ensures that the filter unit runs each day for the time set here. Up to three filtering times can be set each day and copied to another day. Eco mode: if the solar unit or the auxiliary heating runs (the filter then also runs), these operating hours will be subtracted from the filtering times set here.

*Setting range: off, daily 0:00 - 23:59/Default: daily 16:00 - 21:00*

## Relay 1

### 5.4. Relay 1

#### 5.4.1. Function

The function for relay 1 is set here.

*Setting range: Deactivated, Timer, Thermostat/Default: Deactivated*

#### 5.4.2. --

#### 5.4.3. --

#### 5.4.4. Times

If the time function is selected, the daily switch times can be set here. Up to three switch times can be set each day and copied to another day.

*Setting range: off, daily 0:00 - 23:59/Default: off*

# Protections

## 6. Protective functions



The menu "6. Protections/Protective functions" can be used to activate and set various protective functions.



This does not under any circumstances replace the safety facilities to be provided by the customer!

The menu is closed by pressing the "esc" key or selecting "Exit protective functions".



### 6.1. Seizing protection

If the seizing protection is activated, the controller switches the relay in question and the connected consumer on every day at 12:00 (setting "daily") or weekly on Sundays at 12:00 (setting "weekly") for 5 seconds in order to prevent the pump and/or the ball valve or other consumer from sticking after an extended stationary period.

*Setting range R1: daily, weekly, off/Default: off*

*Setting range R2: daily, weekly, off/Default: off*

6.3. --

6.2. --

# Special functions

## 7. Special functions



The menu “7. Special functions” is used to set basic items and expand functions.



Other than the time, all settings may only be made by a specialist.

The menu is closed by pressing the “esc” key or selecting “Exit special functions”.

### 7.1. --

### 7.2. Time and date

This menu is used to set the current time and date.



For analysis of the system data it is essential that the time is set accurately on the controller. Please note that the clock has a 24 hour battery reserve if the mains voltage is interrupted and must therefore be reset afterwards.

### 7.3. --

### 7.4. Commissioning

Starting the commissioning help guides you through the basic settings necessary for commissioning in the correct order and provides brief descriptions of each parameter in the display.

Pressing the “esc” key takes you back to the previous value so you can look at the selected setting again or adjust it if desired. Pressing the “esc” key more than once takes you back to the selection mode, thus cancelling the commissioning help. (See also “E.2. Commissioning help” on page 13).



May only be started by a specialist during commissioning! Observe the explanations for the individual parameters in these instructions and check whether further settings are necessary for your application.

### 7.5. Factory settings

All of the settings that have been made can be reset, thus returning the controller to its delivery state.



The entire parametrisation, analyses etc. of the controller will be lost irrevocably. The controller must then be commissioned once again.

### 7.6. --

# Special functions

## 7.7. --

## 7.8. Daylight saving time

When this function is active, the controller's clock changes automatically to and from DST (Daylight Saving Time).

*Default: yes Setting: yes, no/Default: yes*

## 7.9. Signal mode

Settings for the filter level switching mode.

Impulse: short signal impulses when switching the pump levels.

Permanent: the switching signal for the pump level is permanently on for the switched level during the pump filtering time.

*Setting range: impulse, permanent/Default: impulse*

## 7.10. 0-10 V Signal

Alternatively to a multistage pump, a variable speed pump can be connected at output V1 via a frequency converter and controlled via a 0-10 V signal. The pump works in a linear fashion between 0 V (pump off) and 10 V (100% pump capacity).

### 7.10.1. Signal at level 1

The value set here appears if the multistage pump runs at level 1.

*Setting range: 1 - 100 %/Default: 33 %*

### 7.10.2. Signal at level 2

The value set here appears via V1 in correspondence to level 2.

*Setting range: 1 - 100 %/Default: 66 %*

### 7.10.3. Signal at level 3

Value set for capacity level 3.

*Setting range: 1 - 100 %/Default: 100 %*

# Menu lock

## 8. Menu lock

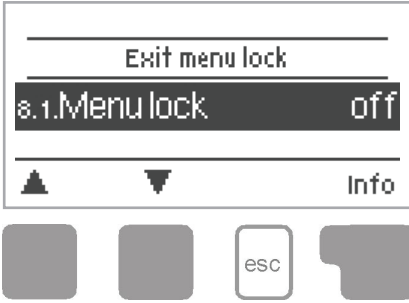

The menu "8. Menu lock" can be used to secure the controller from unintentional changing of the set values.

The menu is closed by pressing the "esc" key or selecting "Exit menu lock".

*The menus listed below remain completely accessible despite the menu lock being activated and can be used to make adjustments if necessary:*

- 2. *Analysis*
- 3. *Display mode*
- 7.2. *Time and date*
- 8. *Menu lock*
- 9. *Service values*

*To lock the other menus select "Menu lock on".*

*To enable the menus again select "Menu lock off".*

*Setting range: on, off/Default: off*

## Service data

### 9. Service data

9.1.	BST3S
9.2.	2015/10/05.1520+U
9.3. Tmin S1	20.0°C

▲ ▼



The menu “9. Service values” can be used for remote diagnosis by a specialist or the manufacturer in the event of an error.



Enter the values at the time when the error occurs e.g. in the table.

The menu can be closed at any time by pressing the “esc” key.

## Language

### 10. Language

Exit language	
10.1. Deutsch	
10.2. English	

▲ ▼ OK



The menu “10. Language” can be used to select the language for the menu guidance. This is queried automatically during initial commissioning.

The choice of languages may differ, however, depending of the device design.

*Default: Deutsch*

# Malfuctions

## Z.1. Malfuctions with error messages

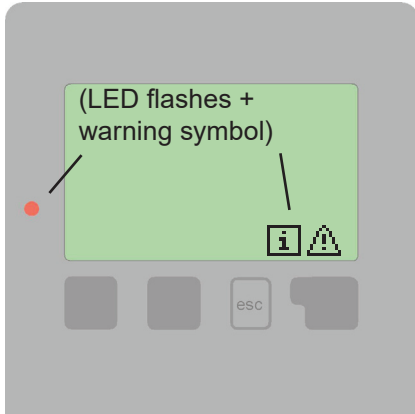

If the controller detects a malfunction, the red light flashes and the warning symbol also appears in the display. If the error is no longer present, the warning symbol changes to an info symbol and the red light no longer flashes.

To obtain more detailed information on the error, press the key under the warning or info symbol.



Do not try to deal with this yourself.  
Consult a specialist in the event of an error!

Possible error messages:

Notes for the specialist:

Restart ----->

Means that the controller was restarted, for example due to a power failure. Check date and time!

# Malfunctions

## Z.2. Replacing the fuse



Repairs and maintenance may only be performed by a specialist. Before working on the unit, switch off the power supply and secure it from being switched on again! Check for the absence of power!



Only use the spare fuse supplied or a fuse of the same design with the following specifications: T 4 A/250 V

### Z.2.1.

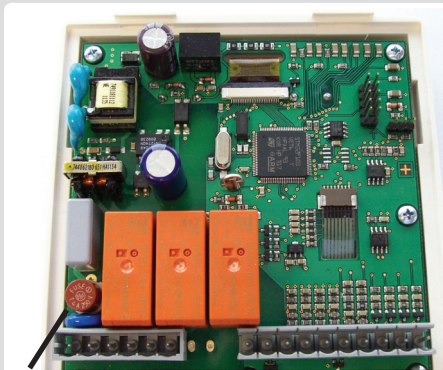

Fuse

If the mains voltage is switched on and the controller still does not function or display anything, the internal device fuse may be faulty. In that case, open the device as described under C, remove the old fuse and check it.

Replace the faulty fuse with a new one, locate the external source of the error (e.g. pump) and repair or replace it.

Then recommission the controller and check the function of the switch outputs in manual mode first as described under “4.2. Manual” on page 18.

## Z.3. Maintenance



In the course of the general annual maintenance of your system you should also have the functions of the controller checked by a specialist and have the settings optimised if necessary.

Performing maintenance:

- Check the time and date (see “7.2. Time and date” on page 26)
- Assess/check plausibility of analyses (see “2. Statistics” on page 16)
- Check the error memory (see “2.5. Message log” on page 16)
- Check the switch outputs/consumers in manual mode (see “4.2. Manual” on page 18)
- If possible, optimise the parameter settings

## Notes



The service values (see “2. Statistics” on page 16) include not only current measurement values and operating states, but also all of the settings for the controller. Write the service values down once after commissioning has been successfully completed.



In the event of uncertainty as to the control response or malfunctions the service values are a proven and successful method for remote diagnosis. Write the service values down (“9. Service values” on page 31) at the time the suspected malfunction occurs. Send the service value table by fax or e-mail with a brief description of the error to the specialist or manufacturer.



To protect against loss of data, record any analyses and data that are particularly important to you (see “2. Statistics” on page 16) at regular intervals.



Filter pump party function: When the “esc” key is pressed for 3 seconds the filter pump switches on for 5 hours.

This can be canceled by pressing the “esc” key again for 3 seconds.

Anschlußbeispiel für BADU Eco Pumpen

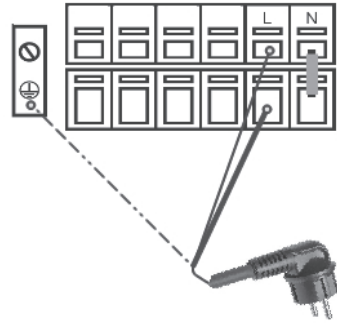
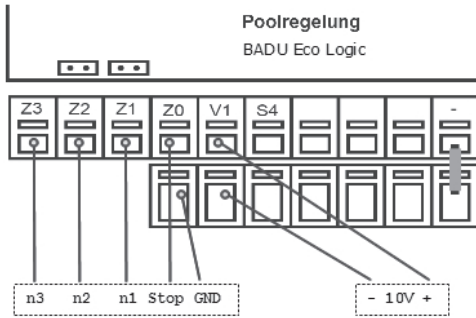

Weiß = n 3  
 Grün = n 2  
 Braun = n 1  
 Rot = Stop  
 Schwarz = GND/common

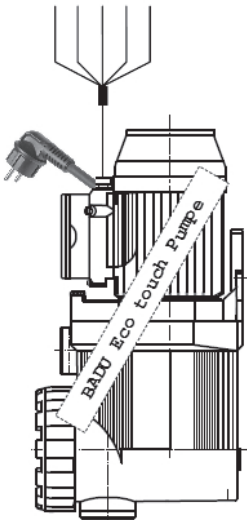

= n 3  
 = n 2  
 = n 1  
 = Stopp  
 = GND

Gelb  
 Grün  
 Braun  
 Rot  
 Schwarz

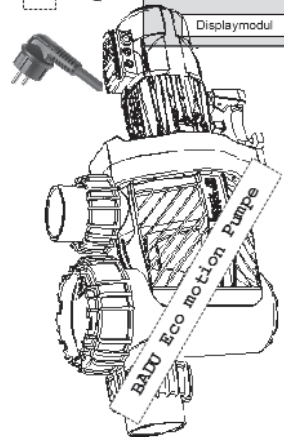
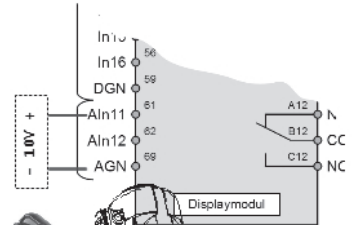
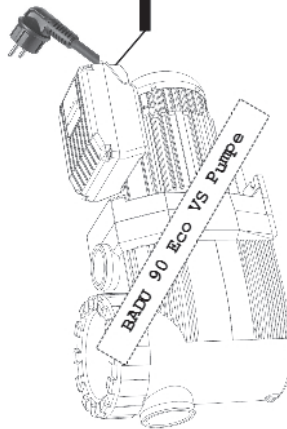

(Datei: 20140220)

Anschlußbeispiel für BADU Easytronic

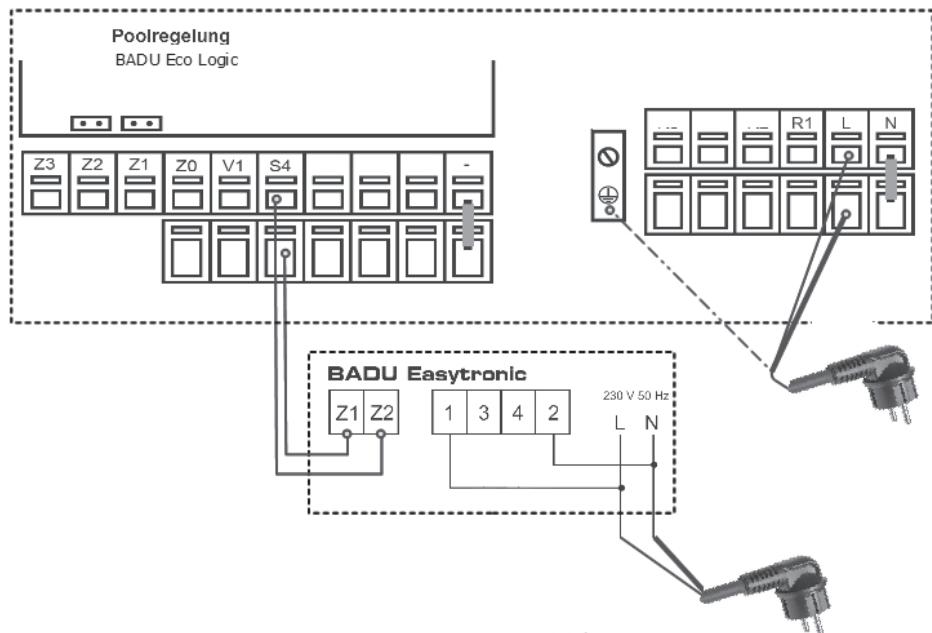

BADU®Easytronic  
Kabelverschraubung für  
potentialfreien Anschluß

An der  
BADU Easytronic  
Einstellen  
Zwangsansteuerung

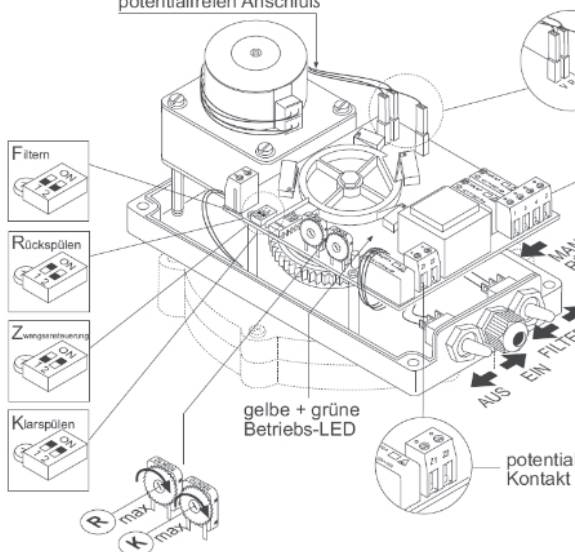

(Datei: 20140220)

---

Commissioner's notes:

---

Hydraulic variant set:

Commissioned on:

Commissioned by:

---

---

Final declaration:

Although these instructions have been created with the greatest possible care, the possibility of incorrect or incomplete information cannot be excluded. Subject as a basic principle to errors and technical changes.

---

Here you will find further FAQs and notes regarding the BADU Eco Logic:

## BADU Eco Logic - capacitor/GoldCap

Within a few minutes the charging capacitor for the control is activated and retains the date and time for min. 24 hours. There are no guarantees that the date and time will be retained for disruptions exceeding this time frame. However it is possible.

All other settings remain unchanged even without the charging capacitor.

## Switch installation

It may be necessary to use a switch for the customer for the stop contact S4.

A hole can be drilled into the low voltage side to insert the switch (IPx4) in order to avoid installing an extra housing.



A  $d=6\text{mm}$  drill should be used. The hole should be positioned as shown to the right.

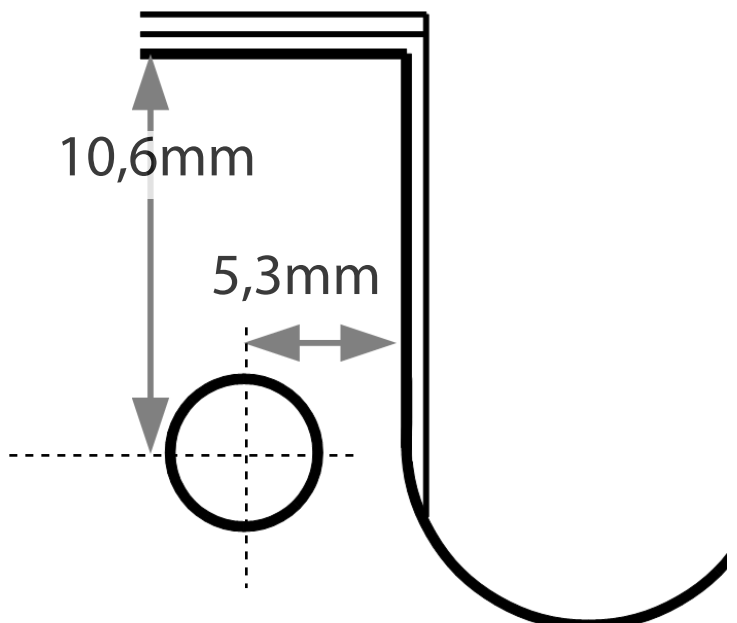

Article:

5880800212 Kippschalter

5880800213 Kappe für Kippschalter

5811250600 Beilagscheibe

Déclaration CE de conformité / EC declaration of conformity / Dichiarazione CE di conformità / EG-veklaring van overeenstemming / EU-yhtäpitävyysilmoitus / Declaración de conformidad / Deklaracja zgodności CE / ES prohlášení o shodě / ES vyhlásenie o zhode / EF-overensstemmelseerklæring / EG-deklaration om överensstämmelse / AT Uygunluk Beyanı / Декларация соответствия ЕС

197

**Hiermit erklären wir, dass das Pumpenaggregat / Maschine**

Par la présente, nous déclarons que le groupe moteur-pompe / Herewith we declare that the pump unit / Si dichiara, che la pompa / hiermee verklaren wij, dat het pompaggregaat / Täten ilmoitamme, että pumpulaite / Por la presente declaramos que la unidad de bomba / Niniejszym oświadczamy, że pompa / Prohlásujeme, že níže uvedené čerpadlo / Vyhlasujeme, že nižšie uvedené čerpadlo: / Hermed erklærer vi, at pumpeaggregatet/maskinen / Härmed tillkännager vi att pumpaggregatet/maskinen / A şağıda adı geçen pompa ünitesinin/makinenin / Настоящим мы заявляем, что насосный агрегат/машина

**Baureihe**

Série / Series / Serie / Serie / Mallisarja / Serie / Typoszereg / Série / Série / Serie / Serie / Seri / Серии

**BADU Logic 1****BADU Logic 2****BADU Logic 3****BADU Eco Logic****folgenden einschlägigen Bestimmungen entspricht:**

correspond aux dispositions pertinentes suivantes: / complies with the following provisions applying to it: / è conforme alle sequenti disposizioni pertinenti: / in de door ons geleverde uitvoering voldoet aan de eisen van de in het vervolg genoemde bepalingen: / cumple las siguientes disposiciones pertinentes: / vastaa seuraavia asiaan kuuluvia määräyksiä: / odpowiada następującym normom: / je v souladu s požadavky směrníc, které se na něj vztahují: / je v súlade s požiadavkami smerníc, ktoré sa na ne vzťahujú: / opfylder følgende gældende bestemmelser: / uppfyller följande tillämpliga bestämmelser: / aşağıda belirtilen geçerli yönetmeliklere uygun olduğunu beyan ediyoruz: / отвечает соответствующим положениям:

**EG-Niederspannungsrichtlinie 2014/35/EU**

Directives basse tension 2014/35/UE / Low voltage directive 2014/35/EU / CE-Direttiva di bassa tensione 2014/35/EU / EG-laagspanningsrichtlijn 2014/35/EU / EU-pienjännitedirektiivi 2014/35/EU / directiva de baja tensión 2014/35/UE / Dyrektywa niskonapięciowa 2014/35/UE / nízkonapäťová smernice 2014/35/EU / nízkonapäťová smernica 2014/35/EU / EF-lavspændingsdirektiv 2014/35/EU / EG-lågspänningsdirektivet 2014/35/EU / AT Alçak Gerilim Yönetmeliği 2014/35/EU / Директива ЕС по низким напряжениям 2014/35/EU

**EMV-Richtlinie 2014/30/EU**

Directives CE sur la compatibilité électromagnétique 2014/30/UE / EMC-Machinery directive 2014/30/EU / Direttiva di compatibilità elettromagnetica 2014/30/UE / Richtlijn 2014/30/EU / Sähkömagneettinen yhteensopivuus (EMC) konedirektiivi 2014/30/EU / directiva 2014/30/UE / Dyrektywa kompatybilność elektromagnetyczna (EMC) 2014/30/UE / směrnice o elektromagnetické kompatibilitě 2014/30/EU / smernica o elektromagnetickej kompatibiliti 2014/30/EU / EMC-direktiv 2014/30/EU / EMC-direktivet 2014/30/EU / EMC Yönetmeliği 2014/30/EU / Директива по электромагнитной совместимости 2014/30/EU

**EG-Richtlinie 2002/96/EG (WEEE)**

Directive 2002/96/CE (DEEE) / Directive 2002/96/EC (WEEE) / Direttiva 2002/96/CE (WEEE) / EG-Richtlijn 2002/96/EG (WEEE) / EU-direktiivi 2002/96/EC (WEEE) / CE-Directiva 2002/96/EG (tratamiento de residuos de componentes de aparatos eléctricos y electrónicos en desuso) / Dyrektywa 2002/96/EG (WEEE) / směrnice 2002/96/ES (WEEE) / smernica 2002/96/ES (WEEE) / EF-direktiv 2002/96/EF (WEEE) / EG-direktivet 2002/96/EG (WEEE) / AT Yönetmeliği 2002/96/AT (WEEE) / Директива ЕС 2002/96/EG (WEEE)

**EG-Richtlinie 2011/65/EG (RoHS)**

Directive 2011/65/CE (RoHS) / Directive 2011/65/EC (RoHS) / Direttiva 2011/65/CE (RoHS) / EG-Richtlijn 2011/65/EG (RoHS) / EU-direktiivi 2011/65/EC (RoHS) / CE-Directiva 2011/65/EG (limitación de utilización de determinados productos peligrosos en aparatos eléctricos y electrónicos) / Dyrektywa 2011/65/EG (RoHS) / směrnice 2011/65/ES (RoHS) / smernica 2011/65/ES (RoHS) / EF-direktiv 2011/65/EF (RoHS) / EG-direktivet 2011/65/EG (RoHS) / AT Yönetmeliği 2011/65/AT (RoHS) / Директива ЕС 2011/65/EG (RoHS)

**Angewendete harmonisierte Normen, insbesondere**

Normes harmonisées utilisées, notamment: / Applied harmonized standard in particular / Norme armonizzate applicate in particolare / Gebuikte geharmoniseerde normen, in het bijzonder / Käytettyjä harmonisoituja normeja, erityisesti / Normas armonizadas aplicadas, especialmente / Zastosowane normy zharmonizowane, w szczególności / za použití následujících harmonizovaných norem / za použití následujících harmonizovaných noriem / Anvendte harmoniserede standarder, især / Tillämpade harmoniserade normer, i synnerhet / Uygulananmış harmonize standartlar, özellikle / Исползованные согласованные нормы, в особенности

**EN 60730-2-9:2015 Automat.  
Elektrische Regel- und  
Steuergeräte****EN 60730-1:2000 +A2:2008****EN 61000-3-2:2006 EMV****EN 61000-3-3:2008 EMV**

91233 Neunkirchen am Sand, 17.09.2014

Ort, Datum / Fait à, le / Place, date / Località, data / Plaats, Datum / Paikka, Päiväys / Lugar, Fecha / Miejsce, data / Místo, datum / Miesto, dátum / Sted, dato / Ort, datum / Yer, Tarih

SPECK Pumpen Verkaufsgesellschaft GmbH  
Hauptstraße 3, 91233 Neunkirchen am Sand, Germany  
Adresse / Adresse / Address / Indirizzo / Adres / Osoite / Dirección / Adres / Adresa / Adresa / Adresse / Address / Adres



i.V. S. Watolla, Techn. Leiter

"Directeur Technique / Technical director / Direttore tecnico / Technisch directeur / Kierownik techniczny / Technický reditel / Technický riaditeľ / Teknisk chef / Tekn. Chef / Teknik Müdür / Технический руководитель



A. Herger, Geschäftsführer

Gérant / Director / Amministratore / Bedrijfsleider / Toimitusjohtaja / Gerente / Dyrektor zarządzający / Ředitel / prodeje marketingu / Obchodný riaditeľ / Direktor / Verkställande direktör / Genel Müdür / Директор