

DE	<b>Pumpendatenblatt</b>
EN	<b>Data sheet</b>
FR	<b>Fiche technique pompe</b>
NL	<b>Pompgegevens</b>
IT	<b>Documentazione pompa</b>
ES	<b>Ficha técnica de la bomba</b>

## **BADU**<sup>®</sup> Eco Touch-Pro II

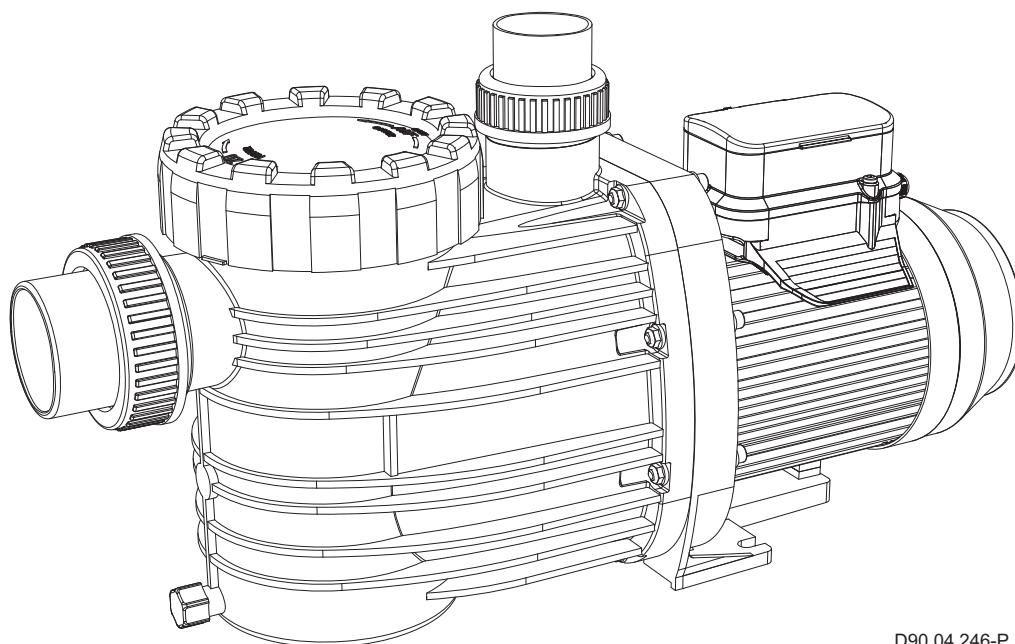

D90.04.246-P





BADU® ist eine Marke der  
SPECK Pumpen Verkaufsgesellschaft GmbH

Hauptstraße 3  
91233 Neunkirchen am Sand, Germany

Telefon 09123 949-0  
Telefax 09123 949-260  
info@speck-pumps.com  
www.speck-pumps.com

Alle Rechte vorbehalten.

Inhalte dürfen ohne schriftliche Zustimmung von  
SPECK Pumpen Verkaufsgesellschaft GmbH weder  
verbreitet, vervielfältigt, bearbeitet noch an Dritte  
weitergegeben werden.

Dieses Dokument sowie alle Dokumente im Anhang  
unterliegen keinem Änderungsdienst!

**Technische Änderungen vorbehalten!**

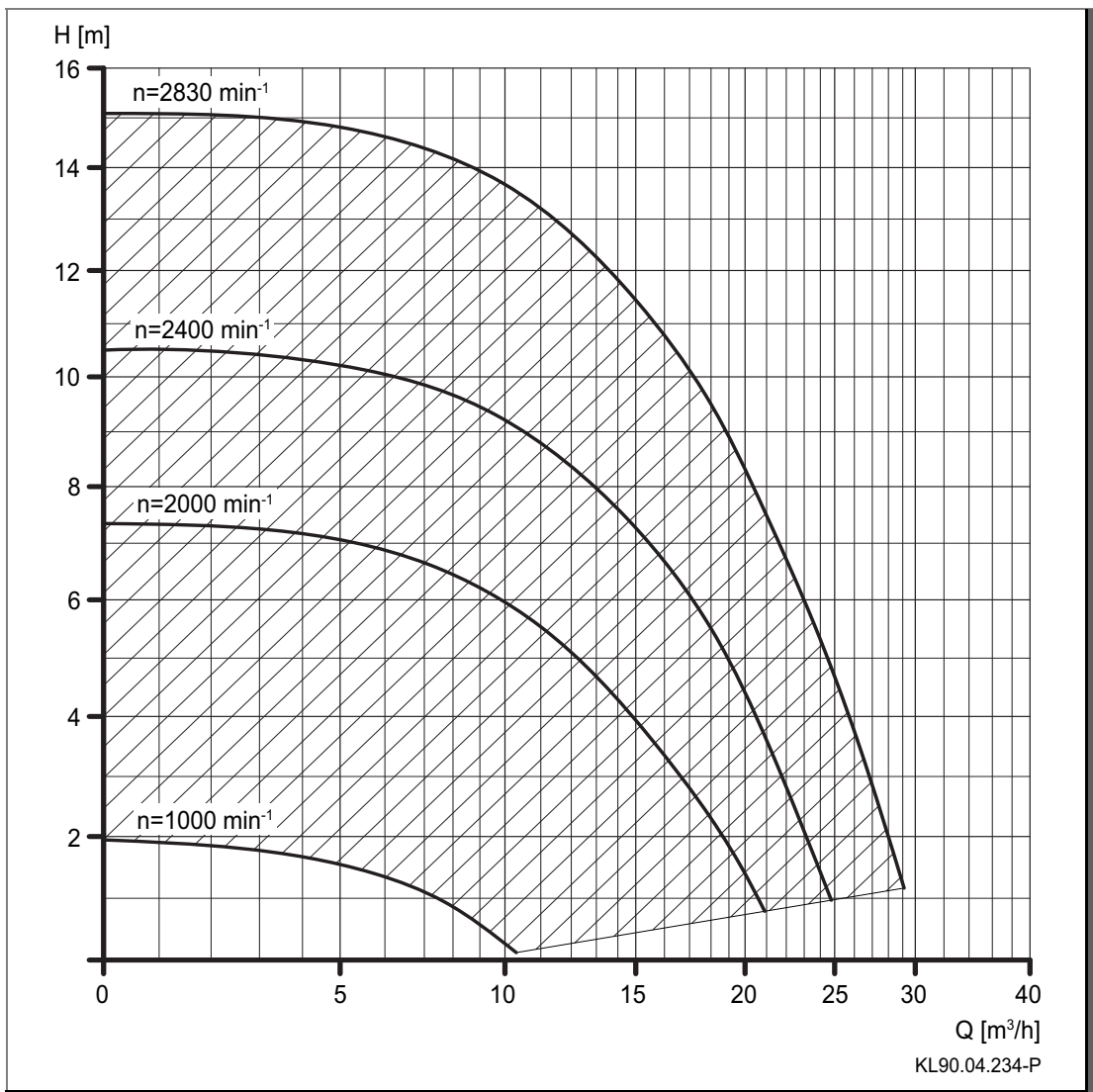
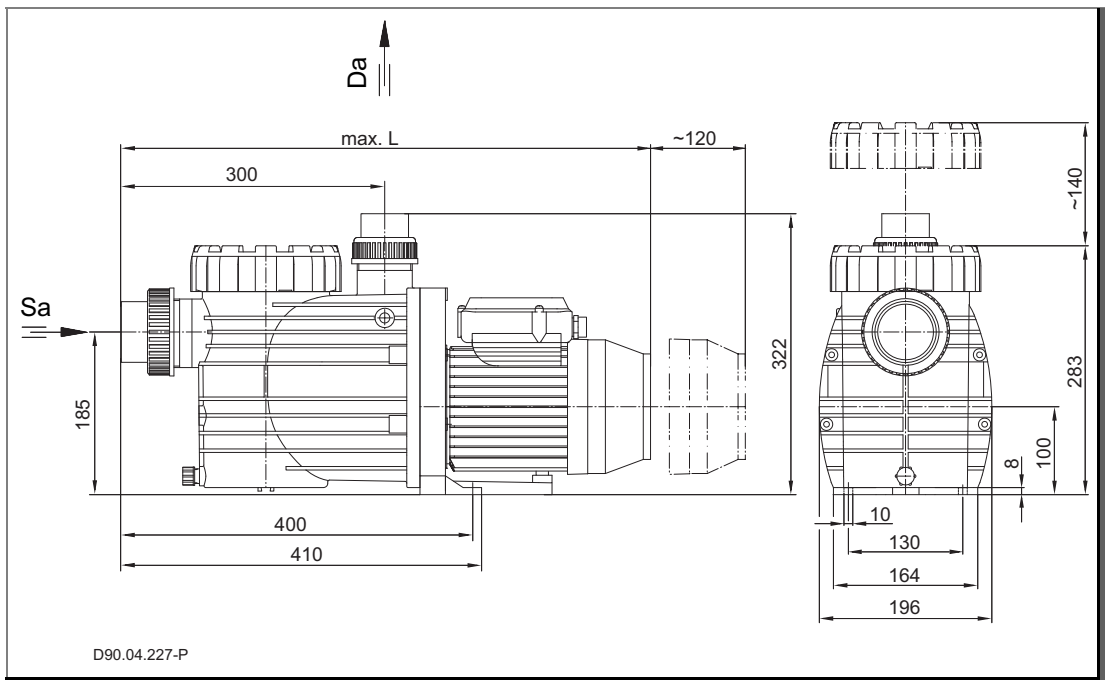

TD 50/60 Hz	Sa [mm]	Da [mm]	d-Saug [mm]	d-Druck [mm]	max. L [mm]
BADU Eco Touch-Pro II	63	50	63	50	602
BADU Eco Touch-Pro II	63	50	63	50	602

### 1~ 230 V

TD 50/60 Hz	n [min <sup>-1</sup> ]	P <sub>1</sub> [kW]	P <sub>2</sub> [kW]	I [A]	Lpa <sup>(1m)</sup> [dB(A)]	Lwa [dB(A)]	m [kg]	WSK/PTC
BADU Eco Touch-Pro II	1000	0,08	0,03	0,60	49,3	57	9,00	●/○
BADU Eco Touch-Pro II	2830	1,05	0,75	6,50	65,8	74	9,00	●/○

TD 50/60 Hz	n [min <sup>-1</sup> ]	H <sub>max.</sub> [m]	SP	Hs [m]	H <sub>z</sub> [m]	IP	W-KI	T [°C]	P-GHI [bar max.]
BADU Eco Touch-Pro II	1000	2,00	●	3	3	55	B	40(60)	2,5
BADU Eco Touch-Pro II	2830	15,0	●	3	3	55	B	40(60)	2,5

## **DE Pumpendatenblatt**

### **Mitgeltende Dokumente**

Zu diesem Pumpendatenblatt gehört die Originalbetriebsanleitung "Normal- und selbstansaugende Pumpen mit/ohne Kunststofflaternen-Ausführung (-AK)". Sie muss für das Bedien- und Wartungspersonal frei zugänglich sein.

## **BADU**<sup>®</sup> Eco Touch-Pro II

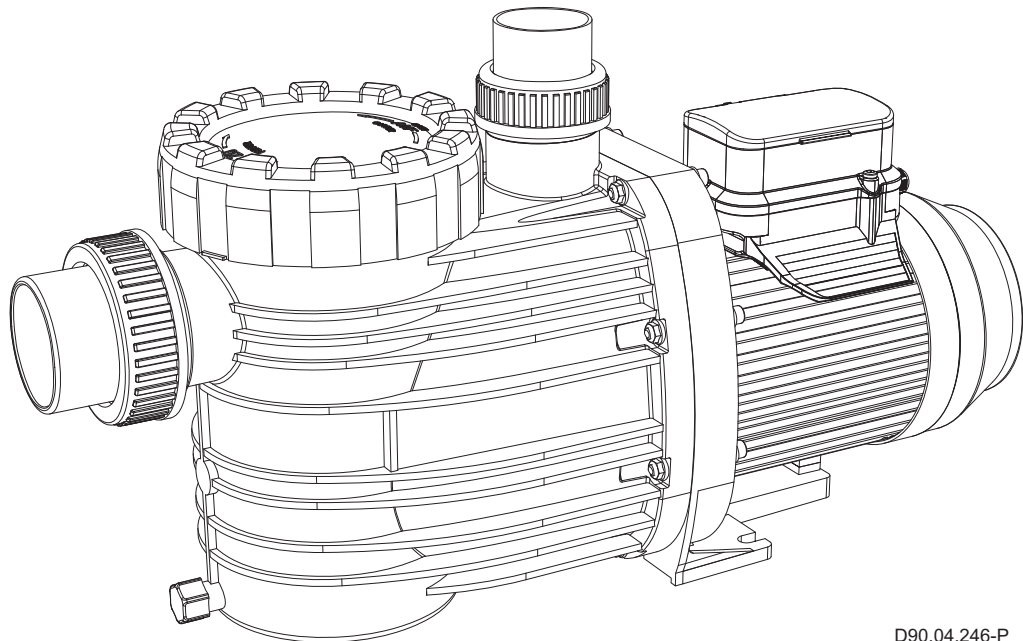

D90.04.246-P

<b>Glossar</b>	
TD	Technische Daten
Sa	Sauganschluss
Da	Druckanschluss
d-Saug	Empfohlener Durchmesser der Saugleitung bis 5 m
d-Druck	Empfohlener Durchmesser der Druckleitung bis 5 m
max. L	Maximale Länge der Pumpe
P <sub>1</sub>	Aufgenommene Leistung
P <sub>2</sub>	Abgegebene Leistung
I	Nennstrom
Lpa (1 m)	Schalldruckpegel in 1 m Entfernung gemessen nach DIN 45635
Lwa	Schalleistung
m	Gewicht
WSK	Wicklungsschutzkontakt oder Motorschutzschalter
PTC	Kaltleiter
H <sub>max.</sub>	Maximale Förderhöhe
SP	Selbstansaugend
Hs; Hz	Geodätische Höhe zwischen Wasserspiegel und Pumpe
Hs	Maximale Saughöhe
Hz	Maximale Höhe bei Zulaufbetrieb
IP	Schutzart des Motors
W-KI	Wärmeklasse
n	Drehzahl
P-GHI	2,5 bar maximaler Gehäuseinnendruck/maximaler Systemdruck
T	Wassertemperatur
●	Ja
○	Nein
T/°C	Erläuterung Wassertemperatur 40 °C (60 °C): 40 °C = gilt für maximale Wassertemperatur im Sinne des GS-Zeichens. (60 °C) = Pumpe ist ohne weiteres für eine maximale Wassertemperatur von 60 °C einsetzbar/ausgelegt.
1~/3~	Geeignet für Dauerbetrieb bei 1~ 220 - 240 V ± 5% 3~ Y/Δ 380 - 420 V/220 - 240 V ± 5% 3~ Y/Δ 660 - 725 V/380 - 420 V ± 5%  Für Normspannung geeignet nach DIN IEC 60038; DIN EN 60034

Bei Sonderspannung und/oder 60 Hz-Ausführung sind die Leistungsdaten vom Pumpentypenschild zu entnehmen. Bei manchen Sondertypen oder – motoren ist das GS-Zeichen nicht vorhanden – ggfs. GS-Zeichen am Pumpentypenschild.

Die Pumpe besitzt einen Permanentmagnet-Motor und ist elektronisch vor Überlastung gesichert.

### Anschluss externer Schaltkontakte

Zur externen Ansteuerung besitzt die Pumpe ein 5-adriges Kabel mit offenen Enden. Zuordnung der Kabel zu den einzelnen Drehzahlen wie folgt:

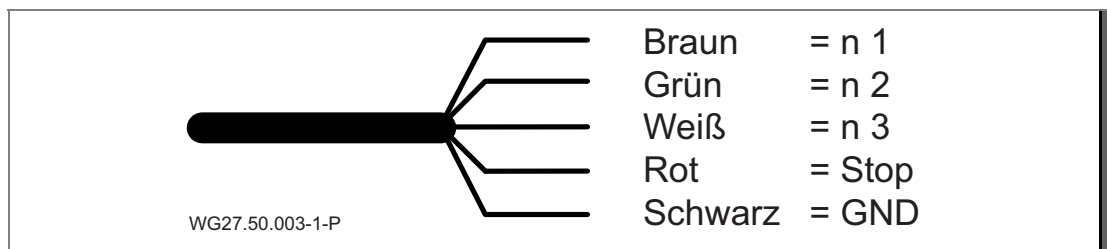

**Die Kabel sind potentialfrei anzuschließen. Kontakte nur einzeln schalten, ansonsten erfolgt keine Aktivierung der gewünschten Drehzahl.**

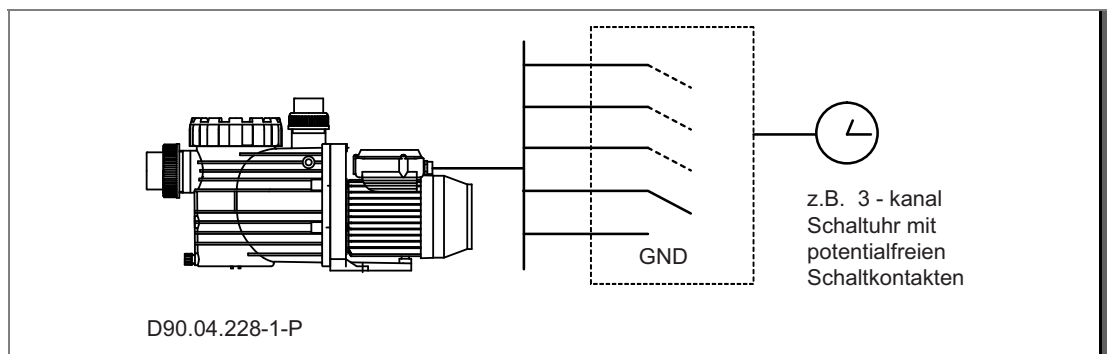

## HINWEIS

Einschalten der Motordrehzahl mittels Handtaster oder externer Schaltkontakte. Dadurch Aktivierung der Schaltkontakte und der zugeordneten Drehzahl.

Startet die Pumpe aus dem Stillstand heraus, läuft sie im Ansaugmodus an und anschließend mit der ausgewählten Festdrehzahl.

Im laufenden Betrieb werden die Festdrehzahlen direkt angefahren, ohne Ansaugzeit.

Wird die externe Ansteuerung nicht benötigt, müssen die Kabelenden isoliert werden.



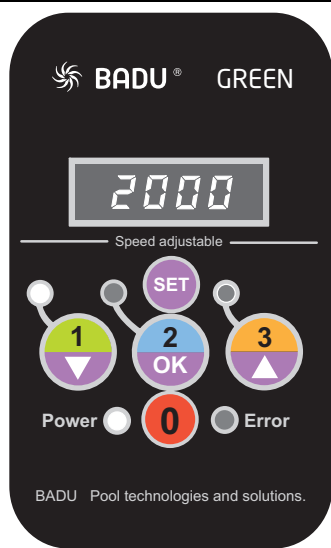

WG27.50.016-P

### Bedienung:

Taste "1", "2" oder "3" drücken, um die voreingestellte Festdrehzahl auszuwählen.

Startet die Pumpe aus dem Stillstand heraus, läuft sie im Ansaugmodus an und anschließend mit der ausgewählten Festdrehzahl.

Solange sich die Pumpe in der Ansaugphase befindet, blinkt die LED der ausgewählten Drehzahl. Im laufenden Betrieb werden die Festdrehzahlen direkt angefahren, ohne Ansaugzeit.

Durch Drücken der Taste "0" wird der Motor gestoppt. Die "Power"-LED blinkt und das Display zeigt "OFF" an.



**Hinweis:** Bei der Verwendung der Pumpe mit einer externen Steuerung, muss beim Programmieren der Drehzahlen und der Ansaugzeit die Verbindung zu der externen Steuerung unterbrochen oder diese von der Netzspannung getrennt werden!

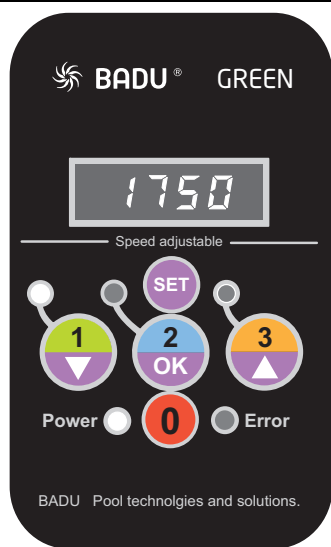

WG27.50.017-P

### Einstellen der Festdrehzahlen:

Die Taste der Festdrehzahl, die verändert werden soll, drücken und danach die "SET"-Taste für mindestens 3 Sekunden halten, bis die Drehzahlanzeige im Display anfängt zu blinken. Nun kann die Drehzahl mit den Tasten "▼ ▲" geändert werden. Zum Speichern der Drehzahl mit "OK" bestätigen. Zum Abbrechen und beibehalten der Ursprungsdrehzahl die "SET"-Taste drücken.



**Hinweis:** Während der Ansaugphase kann die Drehzahl nicht verändert werden. Durch gleichzeitiges drücken und wieder loslassen zweier Festdrehzahlen "1", "2" und/oder "3", kann die Ansaugzeit unterbrochen werden.

 <p style="text-align: right; font-size: small;">WG27.50.018-P</p>	<p><b>Einstellen der Ansaugparameter:</b>          Zum Programmieren der Ansaugzeit muss der Motor gestoppt werden (Taste "0"). Dann wieder die "SET"-Taste für mindestens 3 Sekunden drücken, bis die Drehzahlanzeige im Display anfängt zu blinken. Nun kann die Drehzahl eingestellt werden, mit der der Motor während der Ansaugzeit fahren soll. Mit den Tasten "▼ ▲" kann die Drehzahl geändert und mit "OK" gespeichert werden. Nachdem die Ansaugdrehzahl eingestellt wurde, kann die Länge der Ansaugzeit bestimmt werden. Diese kann von 0 (=Aus) bis 10 Minuten eingestellt werden.</p>
---	--

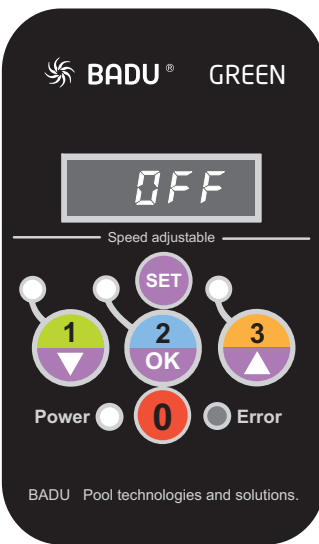
 <p style="text-align: right; font-size: small;">WG27.50.019-P</p>	<p><b>Zurücksetzen / Reset:</b>          Durch Drücken der "SET"-Taste für mindestens 15 Sekunden, kann der Motor wieder zurück in den Auslieferungszustand versetzt werden. Der Motor stoppt und die drei LEDs der Festdrehzahlen leuchten auf.</p>
--	--

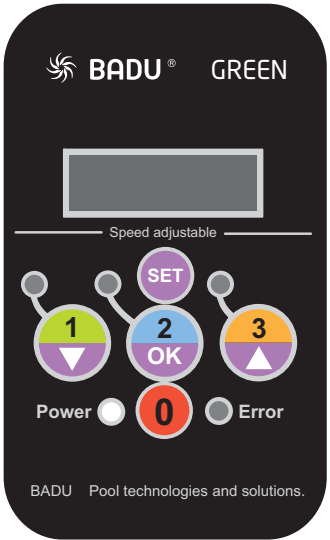
 <p>The image shows a black control panel for a BADU GREEN pump. At the top left is the BADU logo and 'GREEN' text. Below is a rectangular display. Underneath the display is the text 'Speed adjustable'. The panel features several buttons: a green button with '1' and a downward arrow, a blue button with '2' and 'OK', and an orange button with '3' and an upward arrow. Below these are a 'Power' indicator with a white circle, a red button with '0', and an 'Error' indicator with a grey circle. At the bottom left, it says 'BADU Pool technologies and solutions.' and on the right side, vertically, 'WG27.50.020-P'.</p>	<p>Das Display der Steuerung schaltet sich nach 3 Minuten ohne Aktion ab, außer eine externe Steuerung gibt z. B. jede Minute ein Signal an die Pumpe.</p>
<p>Die Pumpe läuft nach einem Spannungsverlust automatisch wieder mit der zuletzt eingestellten Drehzahl an oder bleibt stehen, wenn sie zuvor gestoppt wurde.</p>	

### Übersicht möglicher Betriebs- und Fehlermeldungen

Ist ein Fehler aufgetreten, schaltet der Motor dauerhaft ab. Ausnahmefehler: "Unterspannung". Hier schaltet der Motor wieder selbsttätig ein, sofern die Spannung für mindestens 6 Sekunden über 209 V liegt.

Tritt ein Fehler auf, so ist die Anlage von der Spannungsversorgung zu trennen. Siehe Kapitel 2.2 der Originalbetriebsanleitung "Normal- und selbstansaugende Pumpen mit/ohne Kunststofflaternen-Ausführung (-AK)".

<b>Störung Blinkrate rote LED</b>	<b>Mögliche Ursache</b>	<b>Abhilfe</b>
1	Störung Mikroprozessor	➔ Mikroprozessor startet neu
2	Unterspannung	➔ Spannungsversor- gung < 180 V AC ➔ Steuerung aktiviert sich selbstständig wenn Spannung für mehr als 6 sec. über 209 V ist
3	Temperatur zu hoch/zu niedrig	➔ Temperatur zu hoch > 100 °C ➔ Temperatur zu niedrig < -20 C
4	Überstromauslösung	➔ Strom zu hoch ➔ Internen Überstrom- schutz geschaltet
5	Überspannung	➔ Spannungsversor- gung > 269 V AC
6	Welle blockiert	➔ Last an der Welle zu hoch oder ➔ Motor angehalten
7	Eigentest	➔ Ein oder mehrere Eigentests nicht erfolgreich ausgeführt
8	Motorfehler	➔ Eine oder mehrere Phasen sind nicht angeschlossen

Die folgenden Aufzählungen beziehen sich auf die mitgeltenden Dokumente!

## 8.1 Deckel/Saugsieb demontieren bzw. montieren

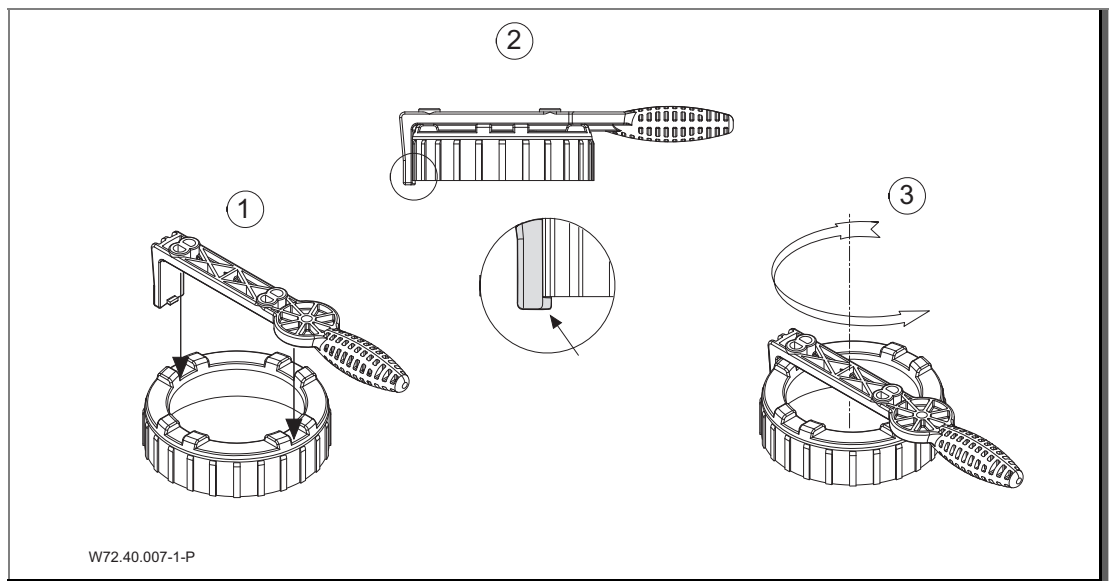

## EN Data sheet

### Related Documentation

The additional information compiled in this data sheet must be kept together with the original operation manual for "Non-self-priming and self-priming pumps with/without plastic lanterns" and must be accessible to the relevant personnel at all times.

## BADU<sup>®</sup> Eco Touch-Pro II

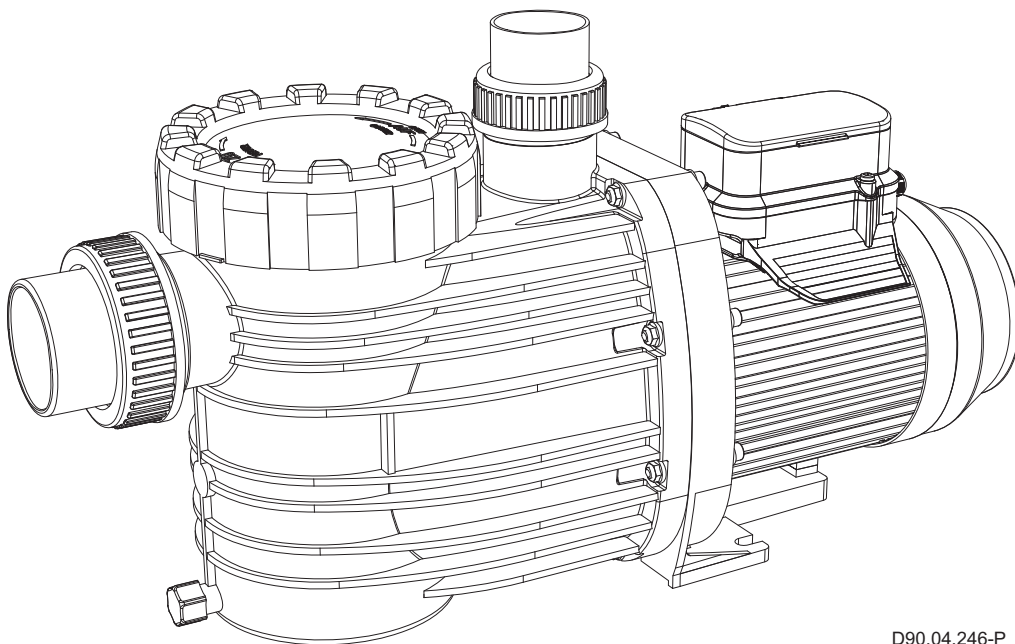

D90.04.246-P

<b>Glossary</b>	
TD	Technical data
Sa	Inlet connection
Da	Outlet connection
d-Saug	Recommended diameter for the suction line from 5 m
d-Druck	Recommended diameter for the pressure line from 5 m
max. L	Maximum length of the pump
P <sub>1</sub>	Power Input
P <sub>2</sub>	Power Output
I	Rated current
Lpa (1 m)	Sound pressure level at 1 m measured in accordance with DIN 45635
Lwa	Acoustic capacity
m	Weight
WSK	Built-in or external overload switch
PTC	PTC Resistor
H <sub>max.</sub>	Total dynamic head
SP	Self-priming
Hs; Hz	Geodetic head between water level and pump
Hs	Total suction head
Hz	Total dynamic head with flooded suction
IP	Type of motor enclosure
W-KI	Class of insulation
n	Motor speed
P-GHI	2,5 bar max. casing pressure/system pressure
T	Water temperature
●	Yes
○	No
T/°C	Clarification of the max. water temperature 40 °C (60 °C): 40 °C = the max. water temperature allowed according to the GS approval. (60 °C) = the pump is designed to withstand a max. water temperature of 60 °C.
1~/3~	Suitable for continuous operation at 1~ 220 - 240 V ± 5% 3~ Y/Δ 380 - 420 V/220 - 240 V ± 5% 3~ Y/Δ 660 - 725 V/380 - 420 V ± 5%  For standard voltage in accordance with DIN IEC 60038; DIN EN 60034

For special voltages and/or the 60 Hz version, the performance data can be taken from the pump name plate. With some special types or motors there is no GS approval – GS approval on pump name plate where applicable.

The pump has a permanently magnetic motor and is electronically protected against overload.

### Connecting external switch contacts

The pump has a 5-wire cable with open ends for external control. Assignment of the cables to the individual speeds is as follows:

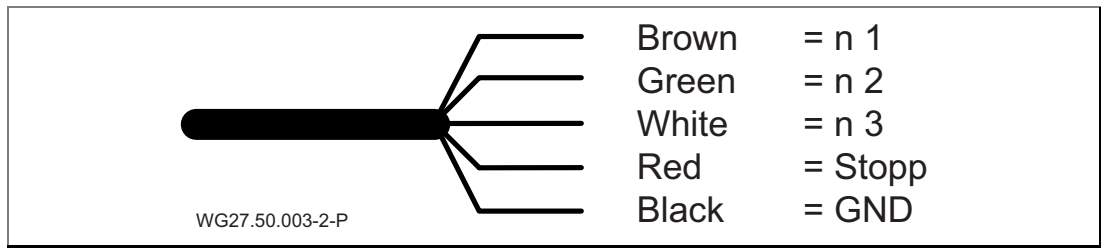

**The cables must be connected potential free. Only switch the contacts individually. Otherwise the desired speed is not activated.**

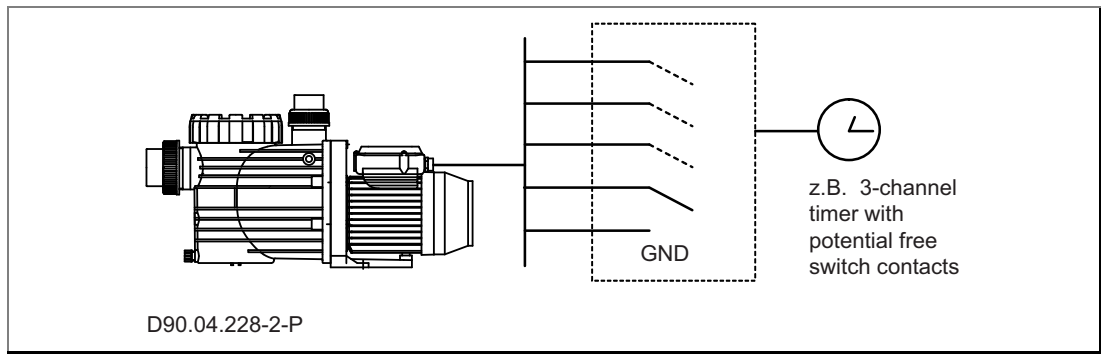

### NOTICE

The motor speed is switched on using the manual button or external switch contacts. The switch contacts and the assigned speed are activated.

If the pump starts from a standstill, it starts up in priming mode and subsequently with the selected fixed speed.

During running operation the pump is started up to the fixed speed directly, without priming time.

If external control is not necessary, the cable ends need to be insulated.

## NOTICE

Installing a flow monitor in the circulation line is recommended so that a failure message can be displayed. A lengthy interruption of the bath water circulation can be prevented in this way.

### Default settings:

Speed:	1 = 2000 min <sup>-1</sup> 2 = 2400 min <sup>-1</sup> 3 = 2830 min <sup>-1</sup>
Priming speed:	= 2830 min <sup>-1</sup>
Priming time:	= 5 minutes
Speeds which can be set:	1000 - 2830 min <sup>-1</sup> (in 50 min <sup>-1</sup> steps)
Priming time which can be set:	0 - 10 minutes (in 1 minute steps)

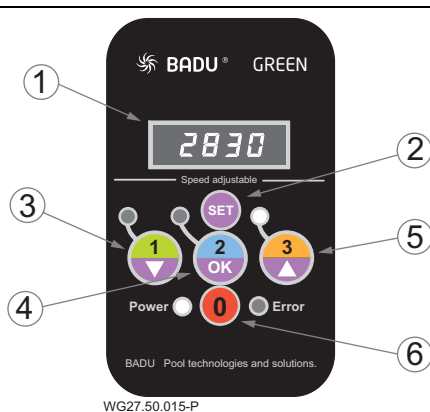

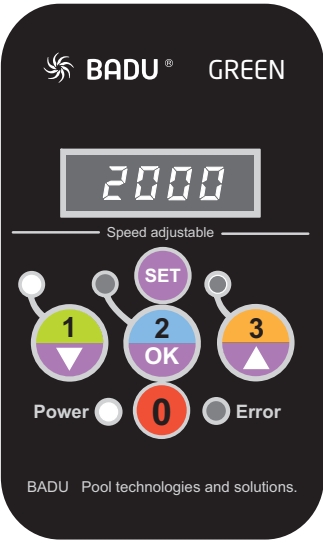

### User interface:

- (1) LED display:** displays the current speed of the motor.
- "Set" button:** used to enter the programming mode or to reset the control.
- Button "1/▼":** used to select the fixed speed / to change in the programming mode.
- Button "2/OK":** used to select the fixed speed / to save in the programming mode.
- Button "3/▲":** used to select the fixed speed / to change in the programming mode.
- Button "0":** to stop the motor.

 <p>The image shows a black control panel for a BADU GREEN pump. At the top, it says 'BADU GREEN'. Below that is a digital display showing '2000'. Under the display is the text 'Speed adjustable'. There are several buttons: a 'SET' button at the top, three buttons labeled '1', '2', and '3' with downward and upward arrows respectively, a '0' button, and an 'OK' button. There are also two indicator lights labeled 'Power' and 'Error'. At the bottom, it says 'BADU Pool technologies and solutions.' and 'WG27.50.016-P' is written vertically on the right side.</p>	<p><b>Operation:</b>          Press button "1", "2" or "3" to select the preset fixed speed.          If the pump starts from a standstill, it starts up in priming mode and subsequently with the selected fixed speed.          As long as the pump is in the priming phase, the LED of the selected speed flashes.          During running operation the pump is started up to the fixed speed directly, without priming time.          The motor is stopped by pressing the button "0". The "Power" LED flashes and the display shows "OFF".</p>
--	--

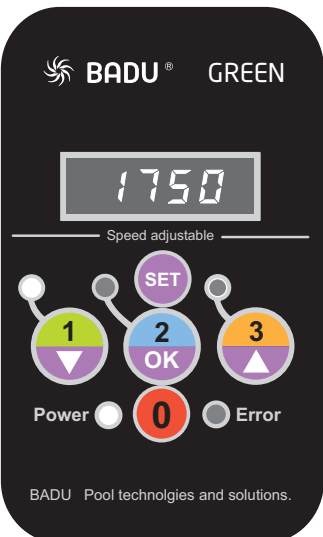
	<p><b>Notice:</b> When the pump is used with an external control, the connection to the external control has to be interrupted or the external control has to be disconnected from the mains voltage when programming the speed and the priming time!</p>
---	---

 <p>The image shows the same control panel as above, but the digital display now shows '1750'. The rest of the panel, including buttons and text, is identical.</p>	<p><b>Setting the fixed speeds:</b>          Press the button of the fixed speed which is to be changed and then keep the "SET" button pressed for at least 3 seconds until the speed displayed in the display begins to flash. Now the speed can be changed with the buttons "▼ ▲". To save the speed confirm with "OK". To cancel and retain the original speed press the "SET" button.</p>
--	---

	<p><b>Notice:</b> During the suction phase it is not possible to change the motor speed. Through pressing and releasing of two speed buttons "1", "2" and/or "3" - the suction time can be interrupted.</p>
---	---

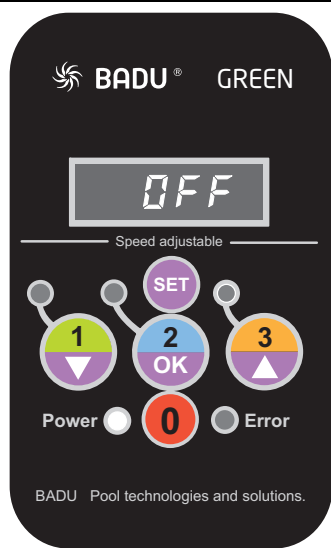

**Setting the priming parameters:**

The motor has to be stopped ("0" button) to programme the priming time. The press the "SET" button again for at least 3 seconds until the speed displayed in the display begins to flash. Now the speed can be set with which the motor is to start up during the priming time. The speed can be changed with the buttons "▼ ▲" and saved with "OK". After the priming speed has been set, the length of the priming time can be specified. The priming time can be set between 0 (=Off) and 10 minutes.

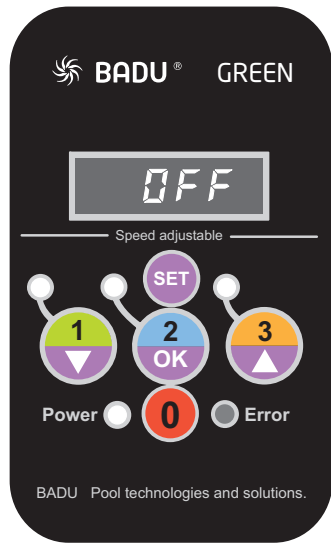

**Resetting:**

The motor can be reset to the state of delivery by pressing the "SET" button for at least 15 seconds. The motor stops and the three LEDs of the fixed speeds light up.

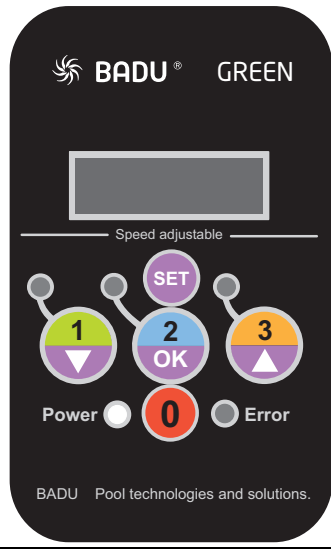

The display of the control unit switched off after 3 minutes without action, except if an external control unit for example emits a signal to the pump every minute.

After a voltage drop the pump automatically starts up again with the speed last set, or remains stopped if it had been stopped beforehand.

## Overview of possible operating and error messages

If an error occurs, the motor switches off permanently. Exception error: "Undervoltage". The motor automatically switches back on as soon as the voltage is over 209 V for at least 6 seconds.

If an error occurs, the system must be disconnected from the power supply. See chapter 2.2 of the original operating manual "non self-priming and self-priming pumps with/without plastic lanterns (AK version)".

Failure blink rate error LED	Possible cause	Remedy
1	Failure in the microprocessor	→ Microprocessor restarts
2	Undervoltage	→ Power supply < 180 V AC → Controller automatically activates when the voltage is over 209 V for at least 6 seconds
3	Temperature too high / too low	→ Temperatur too high > 100 °C → Temperature too low < -20 C
4	Overcurrent triggering	→ Current too high → Internal overcurrent protection switched
5	Overvoltage	→ Power supply > 269 V AC
6	Shaft blocked	→ Load on the shaft too high or → motor stopped
7	Self-test	→ One or more self-tests not run successfully
8	Motor error	→ One or more phases not connected

The following points refers to the related documentation!

## 8.1 Installing or removing the cover/strainer basket

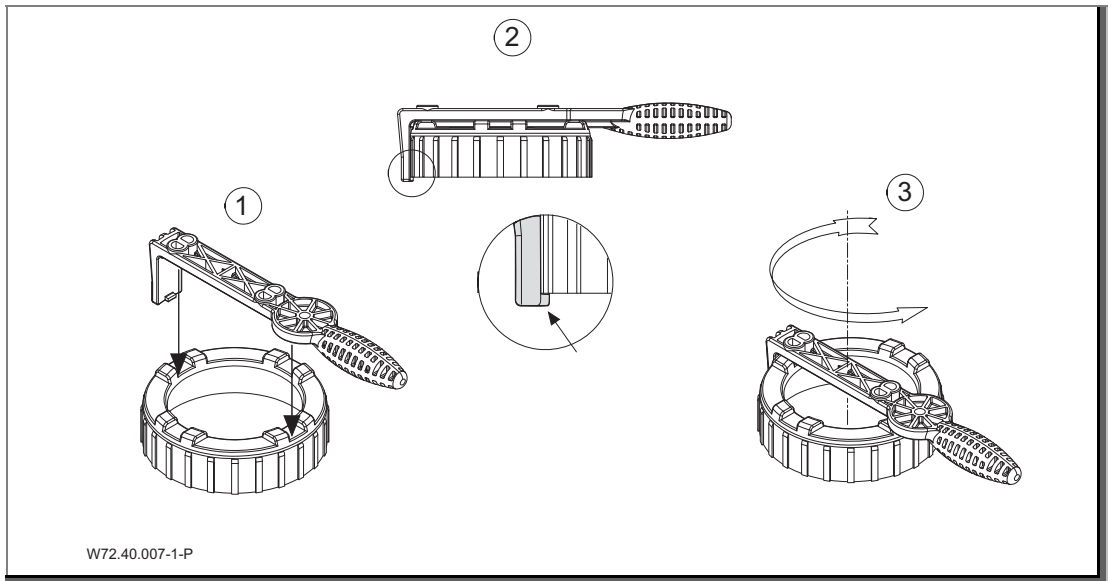

## FR Fiche technique pompe

### Documents applicables

Le présent document fait partie intégrante de la d'utilisation originale pour pompes non auto-amorçantes ou auto-amorçantes avec/sans lantern plastique (exécution AK). Il est recommandé de le tenir accessible aux personnes chargées de l'utilisation et de la maintenance.

## BADU<sup>®</sup> Eco Touch-Pro II

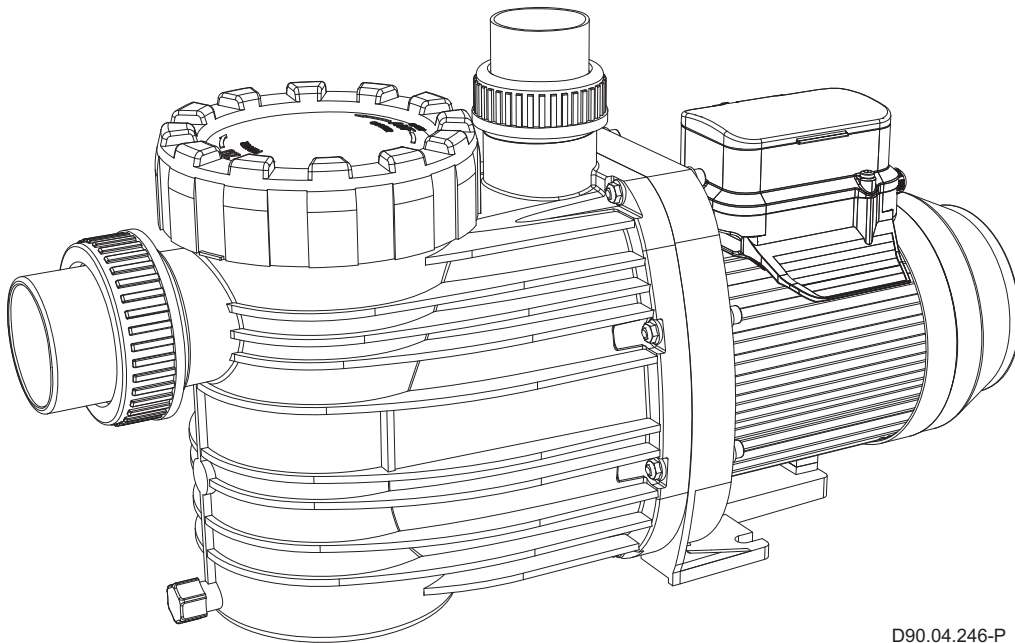

D90.04.246-P

<b>Glossaire</b>	
TD	Données techniques
Sa	Raccordement aspiration
Da	Raccordement refoulement
d-Saug	Diamètre recommandé conduite d'aspiration à 1 m
d-Druck	Diamètre recommandé conduite de refoulement à 1 m
max. L	Longueur maximale de la pompe
P <sub>1</sub>	Puissance électrique
P <sub>2</sub>	Puissance restituée
I	Intensité nominale
Lpa (1 m)	Niveau de pression acoustique à un mètre de distance. Mesures effectuées conformément à DIN 45635
Lwa	Intensité sonore
m	Poids
WSK	Disjoncteur thermique intégré dans le bobinage ou disjoncteur protecteur du moteur
PTC	Thermistor PTC
H <sub>max.</sub>	Hauteur manométrique maximale
SP	Auto-amorçante
Hs; Hz	Hauteur géodésique entre le niveau d'eau et la pompe
Hs	Hauteur d'aspiration maximale
Hz	Hauteur maximale en alimentation
IP	Type de protection
W-KI	Classe d'isolement
n	Vitesse de rotation
P-GHI	2,5 bar de pression maximale à l'intérieur du carter/pression maximale de l'équipement
T	Température de l'eau
●	Oui
○	Non
T/°C	Informations sur la température de l'eau 40 °C (60 °C): 40 °C = valable pour une température maximale en conformité avec le sigle GS. (60 °C) = Cependant, la pompe est facilement utilisable/étalonnée pour une température maximale de l'eau de 60 °C
1~/3~	Adaptée à un fonctionnement ininterrompu à 1~ 220 - 240 V ± 5% 3~ Y/Δ 380 - 420 V/220 - 240 V ± 5% 3~ Y/Δ 660 - 725 V/380 - 420 V ± 5%  Appropriée à une tension conforme aux normes DIN IEC 60038; DIN EN 60034

En cas de tension spéciale et/ou de moteur en 60 Hz, relever les indications de la puissance sur la plaquette signalétique de la pompe. Sur certains types ou moteurs spécifiques le sigle GS n'est pas indiqué – si nécessaire, le sigle GS sera mentionné sur la plaque signalétique de la pompe.

La pompe possède un moteur à entraînement électro magnétique avec protection contre la surcharge.

### Raccordement de contacts de commutation externes

Pour la commande externe, la pompe possède un câble à 5 fils aux extrémités libres. L'affectation des fils du câble aux différentes vitesses de rotation est la suivante:

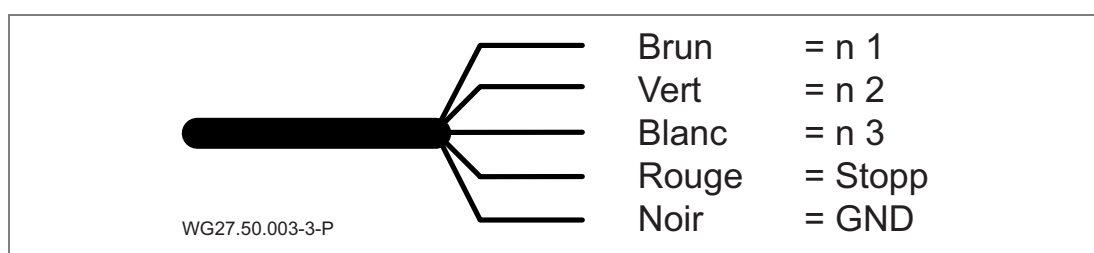

**Les câbles doivent être raccordés libres de potentiel. Activer les contacts uniquement individuellement, sinon l'activation de la vitesse de rotation souhaitée n'aura pas lieu.**

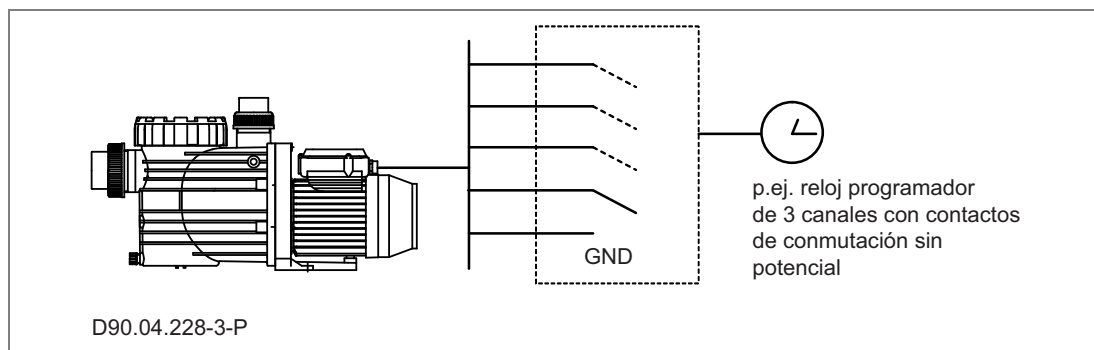

### AVIS

Enclenchement de la vitesse de rotation du moteur à l'aide d'un bouton-poussoir manuel ou de contacts de commutation externes. Il y a ainsi activation des contacts de commutation et de la vitesse de rotation correspondante.

Au démarrage de la pompe, celle-ci fonctionne en mode aspiration et ensuite avec la vitesse de rotation fixe sélectionnée. En cours de fonctionnement, les vitesses de rotation fixes sont atteintes directement, sans temps d'aspiration.

Lorsque la commande externe n'est pas nécessaire, les extrémités des câbles doivent être isolées.

## AVIS

Le montage d'un contrôleur de débit dans la tuyauterie est recommandé afin de permettre l'affichage d'un message d'erreur. Ceci afin d'éviter une trop longue interruption de la circulation de l'eau de la piscine

### Préréglage:

Vitesse:	1 = 2000 min <sup>-1</sup> 2 = 2400 min <sup>-1</sup> 3 = 2830 min <sup>-1</sup>
Vitesse d'aspiration:	= 2830 min <sup>-1</sup>
Temps d'aspiration:	= 5 minutes
Vitesses réglables:	1000 - 2830 min <sup>-1</sup> ( <i>par intervalles de 50 min<sup>-1</sup></i> )
Temps d'aspiration réglable:	0 - 10 min. ( <i>pas intervalles d'une min</i> )

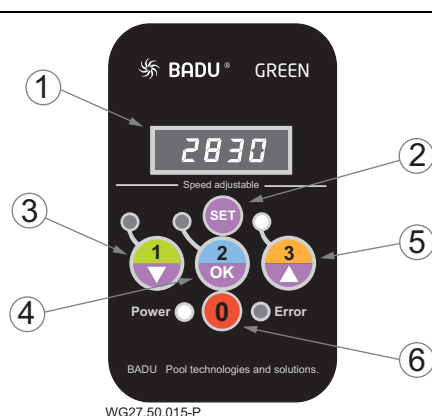

### Interface de commande:

- (1) Affichage LED:** indique la vitesse de rotation actuelle du moteur.
- (2) Touche "SET":** sert à parvenir dans le mode de programmation ou à réinitialiser la commande.
- (3) Touche "1/▼":** sert à la sélection de la vitesse de rotation fixe / à la modification dans le mode de programmation.
- (4) Touche "2/OK":** sert à la sélection de la vitesse de rotation fixe / à l'enregistrement dans le mode de programmation.
- (5) Touche "3/▲":** sert à la sélection de la vitesse de rotation fixe / à la modification dans le mode de programmation.
- (6) Touche "0":** arrêt du moteur.

 <p>The image shows a black rectangular control panel for a BADU GREEN pump. At the top left is the BADU logo and 'GREEN' text. Below is a digital display showing '2000'. Underneath the display is the text 'Speed adjustable'. The panel features several buttons: a 'SET' button at the top, three speed selection buttons labeled '1', '2', and '3' with up/down arrows, a '0' button, and 'Power' and 'Error' indicator lights. The bottom of the panel has the text 'BADU Pool technologies and solutions.' and a vertical model number 'WG27.50.016-P' on the right side.</p>	<p><b>Mise en service:</b>  Appuyer sur la touche "1", "2" ou "3" pour sélectionner la vitesse de rotation fixe prédéfinie.  Au démarrage de la pompe, celle-ci tourne en mode aspiration et ensuite avec la vitesse de rotation fixe sélectionnée.  Aussi longtemps que la pompe est en phase d'aspiration, la LED de la vitesse de rotation sélectionnée clignote.  En cours de fonctionnement, les vitesses de rotation fixes sont atteintes directement, sans temps d'aspiration.  En appuyant sur la touche "0", le moteur est coupé. La LED "Power" clignote et l'écran affiche "OFF".</p>
--	--

	<p><b>Indication:</b> En cas d'utilisation de la pompe avec une commande externe, pendant la programmation des vitesses de rotation et du temps d'aspiration, la liaison à la commande externe doit être interrompue ou séparée de la tension de réseau!</p>
--	--

 <p>The image shows the same control panel as above, but the digital display now shows '1750'. The '1' button has a downward arrow, and the '3' button has an upward arrow. The model number 'WG27.50.017-P' is visible on the right side.</p>	<p><b>Réglage des vitesses de rotation fixes:</b>  Appuyer sur la touche de la vitesse de rotation fixe qui doit être modifiée et ensuite sur la touche "SET" pendant au moins 3 secondes, jusqu'à ce que l'affichage de vitesse de rotation à l'écran commence à clignoter. On peut maintenant modifier la vitesse de rotation avec les touches "▼ ▲". Pour enregistrer la vitesse de rotation, confirmer avec "OK". Pour interrompre et conserver la vitesse de rotation antérieure, appuyer sur la touche "SET".</p>
---	---

	<p><b>Indication:</b> Lors de la phase d'aspiration il n'est pas possible de modifier la vitesse de rotation du moteur. Par un appui simultané et court sur les deux touches « 1 », « 2 » et/ou « 3 », vous avez la possibilité d'interrompre la durée d'aspiration.</p>
---	--

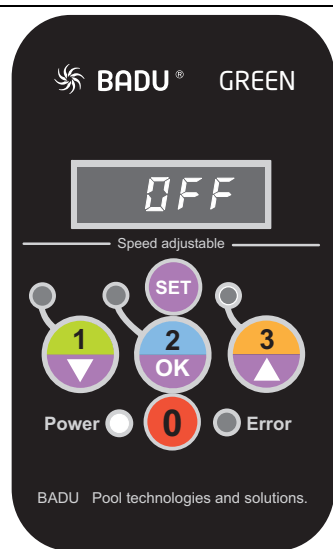

WG27.50.018-P

### Réglage des paramètres d'aspiration:

Pour la programmation du temps d'aspiration, le moteur doit être coupé (touche "0"). Ensuite, appuyer à nouveau pendant au moins 3 seconds sur la touche "SET", jusqu'à ce que l'affichage de vitesse de rotation à l'écran commence à clignoter. On peut maintenant régler la vitesse de rotation du moteur pendant le temps d'aspiration. Avec les touches "▼ ▲", on peut modifier la vitesse du moteur et l'enregistrer avec "OK". Après avoir réglé la vitesse de rotation d'aspiration, on peut déterminer la durée du temps d'aspiration. Celle-ci peut être réglée de 0 (= arrêt) à 10 minutes.

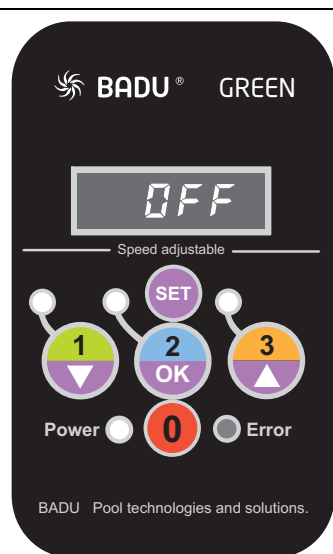

WG27.50.019-P

### Réinitialiser / Reset:

En appuyant sur la touche "SET" pendant au moins 15 secondes, on peut remettre le moteur dans l'état d'origine. Le moteur se coupe et les trois LED des vitesses de rotation fixes s'allument.

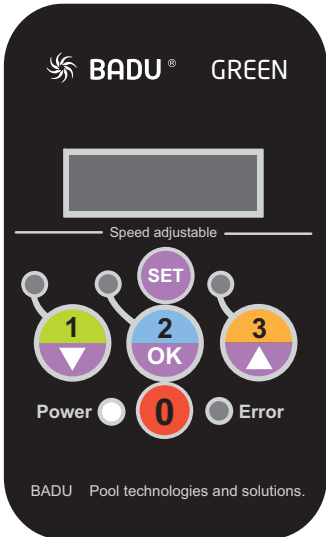
 <p>The image shows a black control panel for a BADU GREEN pump. At the top, it has the BADU logo and 'GREEN' text. Below is a rectangular digital display. Underneath the display is a horizontal line with 'Speed adjustable' written below it. There are three large circular buttons labeled '1', '2', and '3'. Button '1' has a downward arrow, button '2' has 'OK' in the center, and button '3' has an upward arrow. Below these buttons are three smaller buttons: 'Power' (a white circle), '0' (a red circle), and 'Error' (a grey circle). At the bottom left, it says 'BADU Pool technologies and solutions.' and at the bottom right, vertically, 'WG27.50.020-P'.</p>	<p>L'écran de la commande s'éteint après trois minutes sans activité, sauf si une commande externe donne p. ex. à chaque minute un signal à la pompe.</p>
<p>Après une coupure de tension, la pompe tourne automatiquement à nouveau avec la vitesse de rotation réglée en dernier lieu ou demeure à l'arrêt si elle avait été préalablement coupée.</p>	

### **Vue d'ensemble des messages de fonctionnement et de défaut possibles**

En cas de défaut, le moteur se met durablement hors service. Exception: "Soustension". Dans ce cas, le moteur se remet automatiquement en service pour autant que la tension soit supérieure à 209 V pendant au moins 6 s.

En cas de défaut, l'installation doit être isolée de l'alimentation électrique. Cf. chapitre 2.2 de la notice d'utilisation originale pour pompes non auto-amorçantes ou autoamorçantes avec/sans lanterne plastique (exécution AK).

Cadence de clignotement de défaut de la LED d'erreur rouge	Cause possible	Remède
1	Défaut microprocesseur	→ Le microprocesseur redémarre
2	Sous-tension	→ Alimentation en tension < 180 V AC → La commande s'active automatiquement lorsque la tension est supérieure à 209 V pendant plus de 6 s
3	Température trop élevée / trop basse	→ Température trop élevée > 100 °C → Température trop basse < -20 °C
4	Déclenchement par surintensité de courant	→ Surintensité de courant → Disjoncteur de surcharge interne activé
5	Surtension	→ Alimentation en tension > 269 V AC
6	Arbre bloqué	→ Charge à l'arbre trop élevée ou → moteur à l'arrêt
7	Autotest	→ Un ou plusieurs autotests ont échoué
8	Défaut moteur	→ Une ou plusieurs phases ne sont pas raccordées

Les énumérations suivantes se rapportent aux documents d'accompagnement!

## 8.1 Monter/démonter le couvercle/le panier filtrant

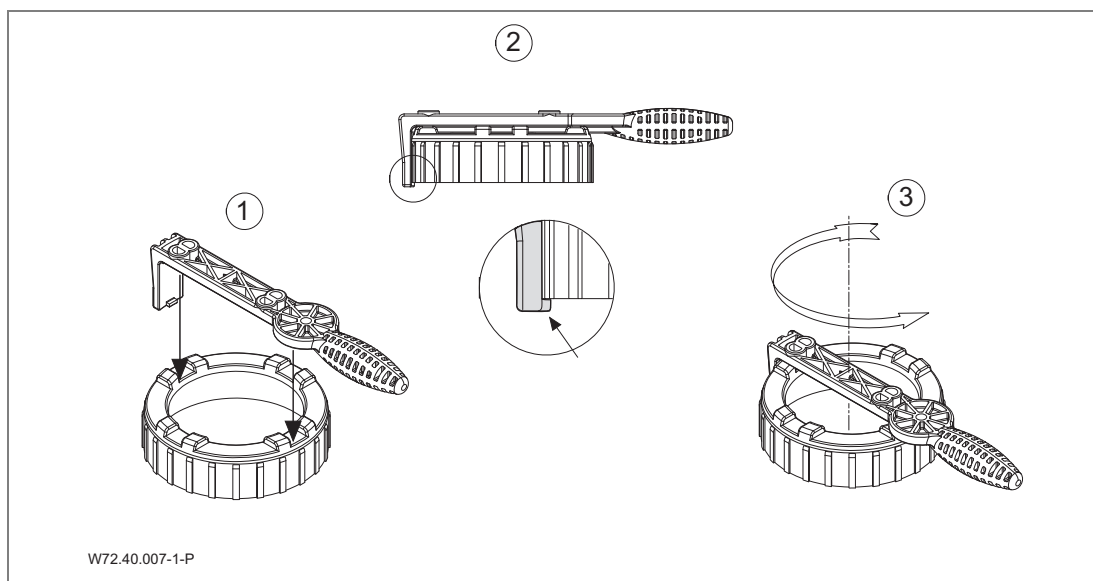

## NL Pompgegevens

### Relevante documenten

Bij deze pompgegevens hoort de originele gebruiksaanwijzing "normal en zelfaanzuigende pompen met/zonder kunststof lantaarn (AK)". Deze moet voor het bedienings- en onderhoudspersoneel te allen tijde beschikbaar zijn.

## BADU<sup>®</sup> Eco Touch-Pro II

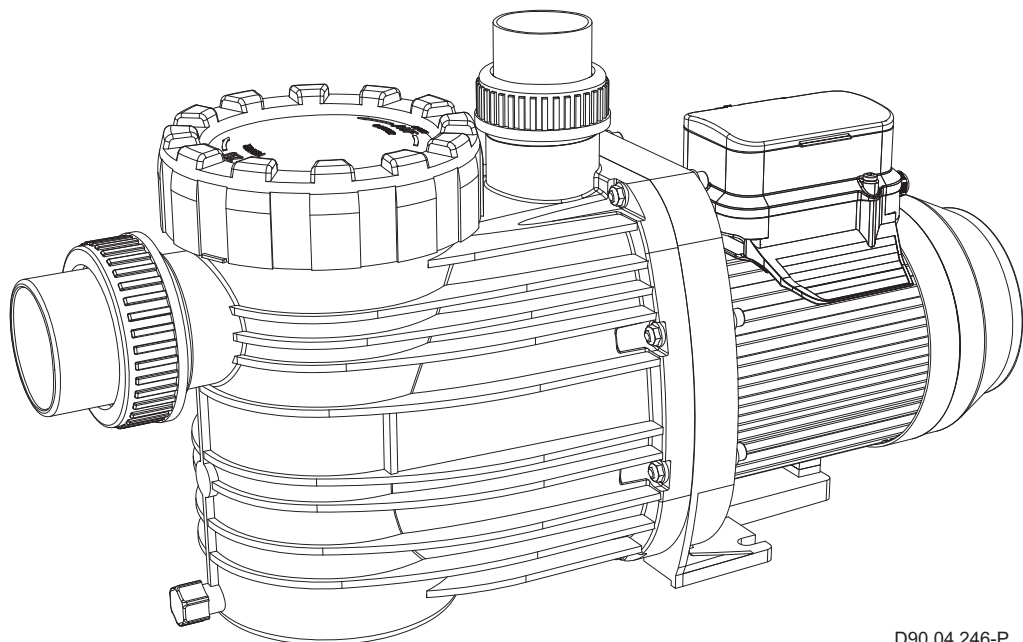

D90.04.246-P

<b>Woordenlijst</b>	
TD	Technische gegevens
Sa	Zuigaansluiting
Da	Persaansluiting
d-Saug	Aanbevolen diameter van de zuigleiding vanaf 5 m
d-Druck	Aanbevolen diameter van de persleiding vanaf 5 m
max. L	Maximale lengte van de pomp
P <sub>1</sub>	Opgenomen vermogen
P <sub>2</sub>	Afgegeven vermogen
I	Nominale stroom
Lpa (1 m)	Geluidsniveau gemeten bij 1 m. afstand volgens DIN 45635
Lwa	Geluidsniveau
m	Gewicht
WSK	Wikkelingsbeschermingscontact of motorbeveiligingsschakelaar
PTC	PTC-voeler
H <sub>max.</sub>	Maximale opvoerhoogte
SP	Zelfaanzuigend
Hs; Hz	Geodetische hoogte tussen het waterniveau en de pomp
Hs	Maximale zuighoogte
Hz	Maximale hoogte bij toeloopbedrijf
IP	Beschermingsklasse
W-KI	Temperatuurklasse
n	Toerental
P-GHI	2,5 bar maximale huisdruk/maximale systeemdruk
T	Watertemperatuur
●	Ja
○	Nee
T/°C	Verklaring watertemperatuur 40 °C (60 °C): 40 °C = max. watertemperatuur in combinatie met het GS-keurmerk. (60 °C) = de pomp is geschikt voor een max. watertemperatuur van 60 °C
1~/3~	Geschikt voor continu gebruik bij 1~ 220 - 240 V ± 5% 3~ Y/Δ 380 - 420 V/220 - 240 V ± 5% 3~ Y/Δ 660 - 725 V/380 - 420 V ± 5%  Voor normspanning volgens DIN IEC 60038; DIN EN 60034

Bij speciale spanning en/of 60 Hz uitvoering zijn de capaciteitsgegevens af te lezen op het typeplaatje. Bij sommige speciale typen of motoren is het GS-teken niet beschikbaar – indien nodig GS-teken op het typeplaatje van de pomp.

De pomp is voorzien van een motor met permanente magneet en is elektronisch beveiligd tegen overbelasting.

### Aansluiting van externe schakelcontacten

Voor externe aansturing is de pomp voorzien van een 5-aderige kabel met open uiteinden. De aders van de kabel zijn als volgt toegewezen aan de betreffende toerentallen:

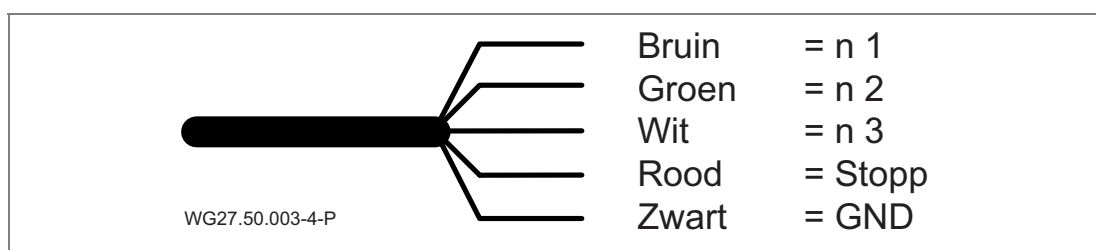

**De kabels moeten potentiaalvrij worden aangesloten. Schakel slechts één contact tegelijk in, anders wordt het gewenste toerental niet geactiveerd.**

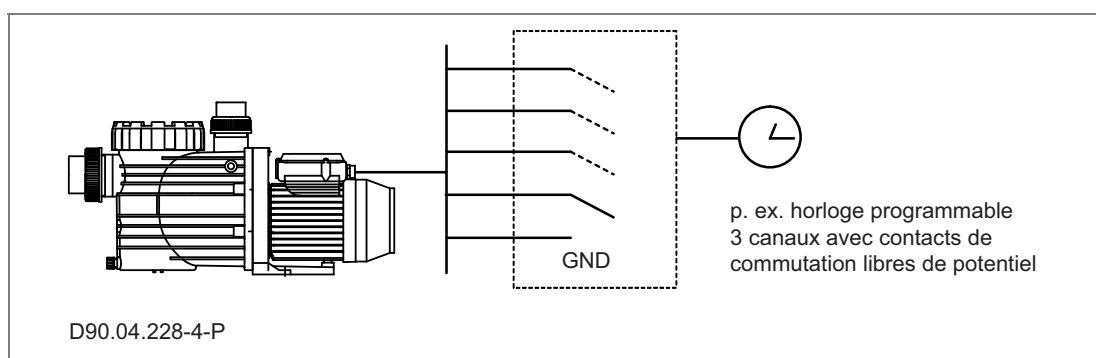

### LET OP

Inschakelen van de motor met de handschakelaar of met externe schakelcontacten. Daardoor wordt het betreffende schakelcontact en het toegewezen toerental geactiveerd.

Wanneer de pomp start vanuit stilstand, loopt deze aan in de aanzuigstand en aansluitend met het geselecteerde vaste toerental.

Wanneer de pomp al in bedrijf is, gaat deze direct naar de vaste toerentallen, zonder aanzuigtijd.

Wanneer externe aansturing niet nodig is, moeten de uiteinden van de kabel worden geïsoleerd.

## LET OP

Het wordt aanbevolen in de circulatieleiding een stromingssensor te installeren waarmee een storingsmelding kan worden gegenereerd. Hierdoor kunnen lange onderbrekingen van de zwembadwatercirculatie worden voorkomen.

### Standaardinstelling:

Snelheid:	1 = 2000 min <sup>-1</sup> 2 = 2400 min <sup>-1</sup> 3 = 2830 min <sup>-1</sup>
Aanzuigsnelheid:	= 2830 min <sup>-1</sup>
Aanzuigtijd:	= 5 minuten
Instelbare snelheden:	1000 - 2830 min <sup>-1</sup> (in stappen van 50 min <sup>-1</sup> )
Instelbare aanzuigtijd:	0 - 10 min. (in stappen van 1 min.)

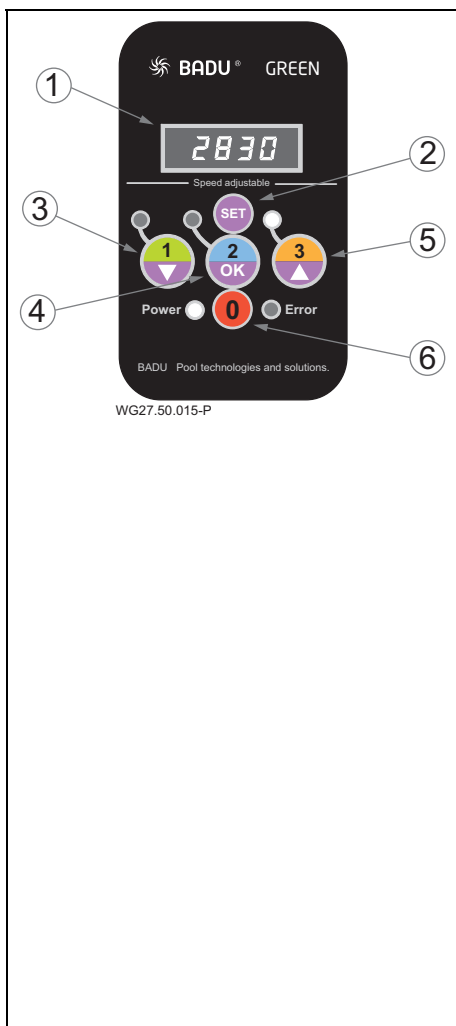

### Bedieningsinterface:

- (1) LED-display:** geeft het huidige toerental van de motor aan.
- (2) "SET"-toets:** om in de programmeerstand te komen resp. om de besturing te resetten.
- (3) Toets "1/▼":** om het vaste toerental te selecteren / voor wijzigen in de programmeerstand.
- (4) Toets "2/OK":** om het vaste toerental te selecteren / voor opslaan in de programmeerstand.
- (5) Toets "3/▲":** om het vaste toerental te selecteren / voor wijzigen in de programmeerstand.
- (6) Toets "0":** om de motor te stoppen

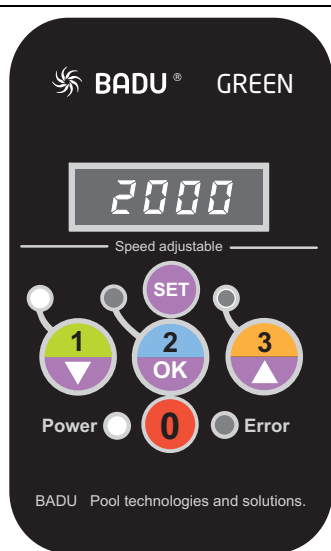

WG27.50.016-P

### Bediening:

Druk op toets "1", "2" of "3" om het standaard vaste toerental te selecteren.

Wanneer de pomp start vanuit stilstand, loopt deze aan in de aanzuigstand en aansluitend met het geselecteerde vaste toerental. Zolang de pomp zich in de aanzuigfase bevindt, knippert de LED van het geselecteerde toerental. Wanneer de pomp al in bedrijf is, gaat deze direct naar de vaste toerentallen, zonder aanzuigtijd. Met de toets "0" wordt de motor gestopt. De "Power"-LED knippert en het display toont de tekst "OFF".



**Aanwijzing:** Bij gebruik van de pomp met externe besturing moet bij het programmeren van de toerentallen en de aanzuigtijd de verbinding met de externe besturing worden onderbroken of moet deze van de netspanning worden losgekoppeld!

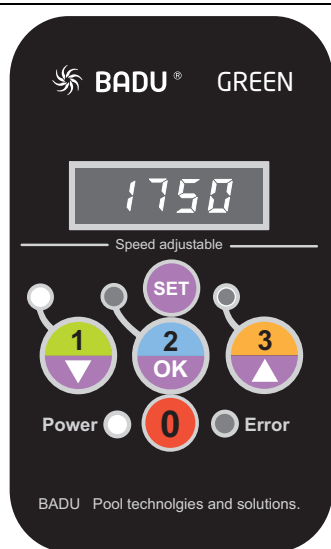

WG27.50.017-P

### Instellen van de vaste toerentallen:

Druk op de toets van het vaste toerental dat moet worden gewijzigd en druk daarna gedurende ten minste 3 sec. op de "SET"-toets tot de toerentalweergave op het display begint te knipperen. Nu kan het toerental met de toetsen "▼ ▲" worden gewijzigd. Bevestig met "OK" om het toerental op te slaan. Druk op "SET" om het instellen te beëindigen en het oorspronkelijke toerental te behouden.

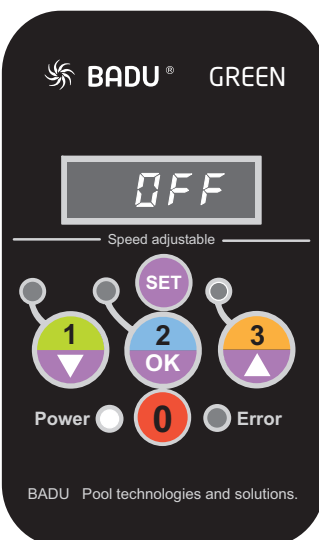

**Aanwijzing:** Tijdens de opstartfase kan het toerental niet gewijzigd worden. Door het gelijktijdig indrukken en weer loslaten van twee knoppen voor het vaste toerental "1", "2" en/of "3", kan de opstartfase onderbroken worden.

 <p>WG27.50.018-P</p>	<p><b>Instellen van de aanzuigparameters:</b></p> <p>Om de aanzuigtijd te programmeren moet de motor worden gestopt (toets "0"). Druk vervolgens weer gedurende ten minste 3 sec. op de "SET"-toets tot de toerentalweergave op het display begint te knipperen. Nu kan het toerental worden ingesteld waarmee de motor gedurende de aanzuigtijd moet lopen. Met de toetsen "▼ ▲" kan het toerental worden gewijzigd en met "OK" worden opgeslagen. Nadat het aanzuigtoerental is ingesteld, kan de duur van de aanzuigtijd worden bepaald. Deze kan van 0 (= uit) tot 10 minuten worden ingesteld.</p>
--	---

 <p>WG27.50.019-P</p>	<p><b>Resetten:</b></p> <p>Door gedurende ten minste 15 seconden op de "SET"-toets te drukken kan de motor worden gereset naar de toestand bij levering. De motor stopt en de drie LED's van de vaste toerentallen gaan branden.</p>
---	--

 <p>The image shows a black control panel for a BADU GREEN pump. At the top left is the BADU logo and 'GREEN' text. Below is a rectangular display screen. Underneath the screen is the text 'Speed adjustable'. The panel features several buttons: a green button with '1' and a downward arrow, a blue button with '2' and 'OK', and an orange button with '3' and an upward arrow. Below these are a 'Power' indicator with a white circle, a red button with '0', and an 'Error' indicator with a grey circle. At the bottom left, it says 'BADU Pool technologies and solutions.' and on the right side, vertically, 'WG27.50.020-P'.</p>	<p>Het display van de besturing schakelt uit wanneer er gedurende drie minuten niet op een toets is gedrukt, tenzij een externe besturing b.v. elke minuut een signaal naar de pomp stuurt.</p>
<p>De pomp loopt na een stroomstoring automatisch weer aan met het laatst ingestelde toerental of blijft stilstaan wanneer deze daarvoor was gestopt.</p>	

### Overzicht van mogelijke bedrijfs- en storingsmeldingen

Wanneer een storing is opgetreden, schakelt de motor permanent uit. Een uitzondering hierop is de storing: "Onderspanning". Hierna schakelt de motor weer vanzelf in zodra de spanning gedurende ten minste 6 sec. meer dan 209 V bedraagt.

Wanneer een storing is opgetreden, moet de installatie worden losgekoppeld van de voeding. Zie hoofdstuk 2.2 van de originele gebruiksaanwijzing "Normaal en zelfaanzuigende pompen met/zonder kunststof lantaarn (AK)".

<b>Storing – knipper-snelheid rode LED Error</b>	<b>Mogelijke Oorzaak</b>	<b>Toelichting</b>
1	Storing microprocessor	→ Microprocessor start opnieuw op
2	Onderspanning	→ Voeding < 180 V AC → Besturing heractiveert zodra de spanning langer dan 6 sec. meer dan 209 V bedraagt
3	Temperatuur te hoog / te laag	→ Temperatuur > 100 °C → Temperatuur < -20 °C
4	Overstroom	→ Stroom te hoog → Interne overstroom-beveiliging geactiveerd
5	Overspanning	→ Voeding > 269 V AC
6	As geblokkeerd	→ Asbelasting te groot of → motor gestopt
7	Zelftest	→ Een of meer zelftests zijn niet succesvol verlopen
8	Motorstoring	→ Een of meer fasen zijn niet aangesloten

Onderstaande opsomming heeft betrekking op de overige relevante documenten!

## 8.1 Deksel/filtermandje demonteren respectievelijk monteren

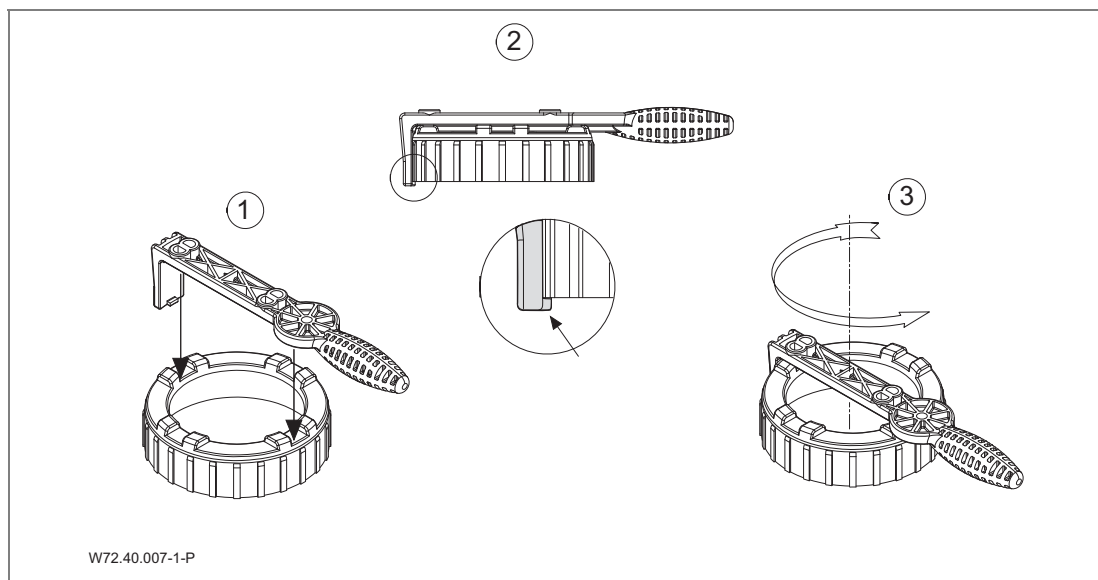

## IT Documentazione pompe

### Altri documenti applicabili

Le istruzioni di funzionamento originali "Pompe aspirazione normale e autodescanti, con e senza campana - esecuzione (AK)" fanno parte a questa documentazione pompa. Queste devono essere ben accessibili per il personale di servizio e per il personale di assistenza.

## BADU<sup>®</sup> Eco Touch-Pro II

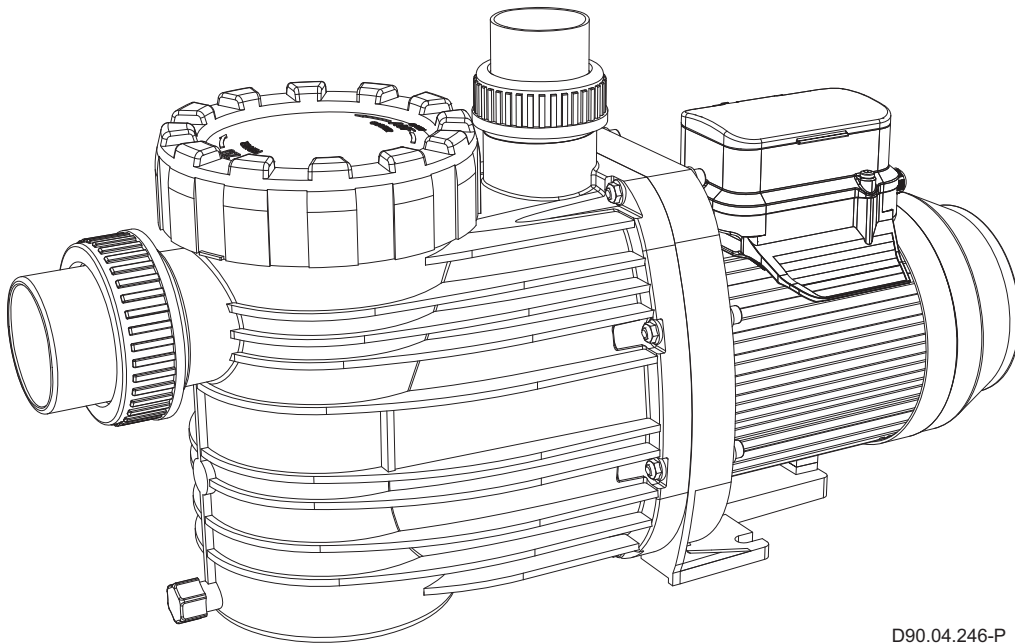

D90.04.246-P

<b>Glossario</b>	
TD	Dati tecnici
Sa	Raccordo aspirazione
Da	Raccordo mandata
d-Saug	Diametro aspirazione consigliato da 5 m
d-Druck	Diametro mandata consigliato da 5 m
max. L	Lunghezza massima della pompa
P <sub>1</sub>	Potenza assorbita
P <sub>2</sub>	Potenza resa
I	Corrente nominale
Lpa (1 m)	Livello di pressione acustica in 1 m di distanza. Misurato a norma DIN 45635
Lwa	Potenza acustica
m	Peso
WSK	Contatto di terra dell'avvolgimento oppure salvamotore
PTC	Conduttore a freddo
H <sub>max.</sub>	Prevalenza massima
SP	Autoadescante
Hs; Hz	Altezza geodetica tra livello dell'acqua e pompa
Hs	Altezza massima aspirazione
Hz	Altezza massima a funzionamento sottobattente
IP	Tipo di protezione motore
W-KI	Classe isolamento
n	Numero di giri
P-GHI	2,5 bar massima pressione interna corpo/massima pressione sistema
T	Temperature acqua
●	Sì
○	No
T/°C	Spiegazione temperatura acqua 40 °C (60 °C): 40 °C = temperatura massima dell'acqua ai sensi del marchio. (60 °C) = la pompa può senz'altro funzionare anche con una temperatura acqua massima di 60 °C
1~/3~	Adatta per funzionamento continuo a 1~ 220 - 240 V ± 5% 3~ Y/Δ 380 - 420 V/220 - 240 V ± 5% 3~ Y/Δ 660 - 725 V/380 - 420 V ± 5%  Adatta per tensione standard secondo normative DIN IEC 60038; DIN EN 60034

Con tensione speciale e/o esecuzione 60 Hz i dati di prestazione sono da prendere dalla targhetta pompa. In alcuni modelli speciali o motori speciali il marchio GS non è presente – eventualmente marchio GS sulla targhetta pompa.

La pompa possiede un motore a magneti permanenti ed è protetta elettronicamente dal sovraccarico.

### Collegamento di contatti di commutazione esterni

Per il comando esterno, la pompa possiede un cavo a 5 conduttori con estremità aperte. I conduttori del cavo sono associati ai seguenti numeri di giri:

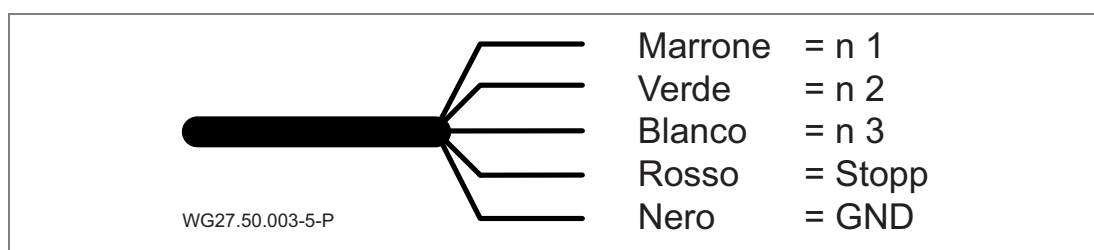

**Il cavo deve essere collegato a morsetti a potenziale zero. Commutare i contatti solo singolarmente, altrimenti il numero di giri desiderato non si attiva.**

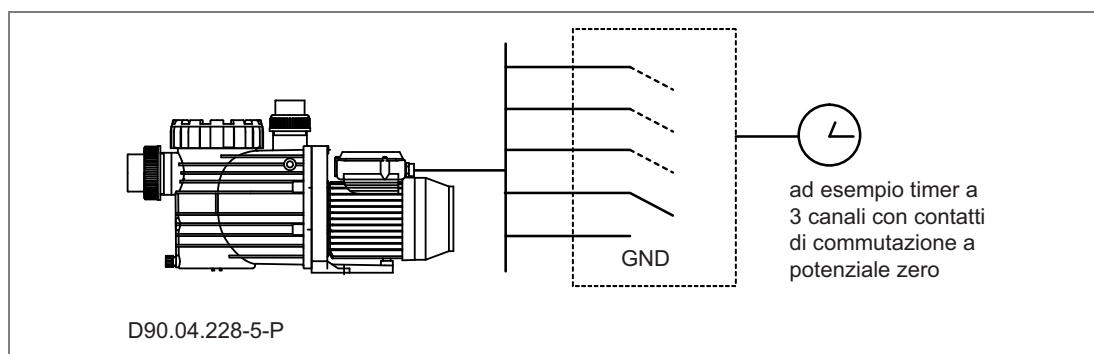

## AVVISO

Attivazione del numero di giri del motore mediante pulsanti manuali o contatti di commutazione esterni. In tal modo si attivano i contatti di commutazione ed il numero di giri associato.

Avviando la pompa da ferma, essa inizia a funzionare in modalità di aspirazione e poi con il numero di giri fisso selezionato.

A pompa in funzione, i numeri di giri fissi vengono raggiunti direttamente senza tempo di aspirazione.

Se il comando esterno non è necessario, le estremità del cavo devono essere isolati.

## AVVISO

È consigliabile montare un regolatore di portata nella tubazione di circolazione in modo che venga visualizzato un messaggio di guasto. In questo modo si può evitare un'interruzione relativamente lunga del circuito dell'acqua da bagno.

### Impostazione predefinita:

Velocità:	1 = 2000 min <sup>-1</sup> 2 = 2400 min <sup>-1</sup> 3 = 2830 min <sup>-1</sup>
Velocità in modalità di aspirazione:	= 2830 min <sup>-1</sup>
Tempo di aspirazione:	= 5 minuti
Velocità regolabili:	1000 - 2830 min <sup>-1</sup> (ad incrementi di 50 min <sup>-1</sup> )
Tempo di aspirazione regolabile:	0 - 10 Min. (ad incrementi di 1 min)

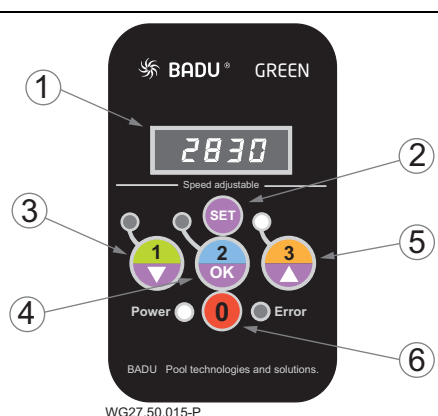



### Pannello di controllo:

- (1) Display a LED:** visualizza il numero di giri attuale del motore.
- (2) Tasto "SET":** per accedere alla modalità di programmazione o per resettare la centralina di comando.
- (3) Tasto "1/▼":** per selezionare il numero di giri fisso / per modificare nella modalità di programmazione.
- (4) Tasto "2/OK":** per selezionare il numero di giri fisso / per salvare nella modalità di programmazione.
- (5) Tasto "3/▲":** per selezionare il numero di giri fisso / per modificare nella modalità di programmazione.
- (6) Tasto "0":** per arrestare il motore.

	<p><b>Comando:</b>          Premere il tasto "1", "2" o "3" per selezionare il numero di giri fisso preimpostato.          Avviando la pompa da ferma, essa inizia a funzionare in modalità di aspirazione e poi con il numero di giri fisso selezionato.          Finché la pompa si trova in modalità di aspirazione, il LED del numero di giri selezionato lampeggia.          A pompa in funzione, i numeri di giri fissi vengono raggiunti direttamente senza tempo di aspirazione.          Premendo il tasto "0", il motore si arresta. Il LED "Power" lampeggia ed il display visualizza "OFF".</p>
---	---

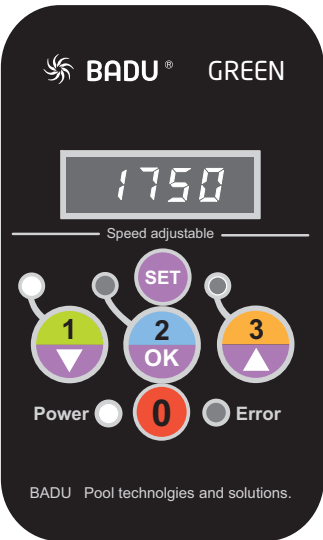
	<p><b>Avviso:</b> Utilizzando il pompa con una centralina di comando esterna, prima di programmare il numero di giri ed il tempo di aspirazione è necessario interrompere il collegamento con la centralina di comando esterna o staccare quest'ultima dalla tensione elettrica!</p>
---	--

	<p><b>Impostazione dei numeri di giri fissi:</b>          Premere il tasto del numero di giri fisso da modificare e quindi premere il tasto "SET" e tenerlo premuto per almeno 3 secondi finché l'indicazione del numero di giri sul display non inizia a lampeggiare. Ora il numero di giri può essere modificato con i tasti "▼ ▲". Per salvare il numero di giri confermare con il tasto "OK". Per annullare e mantenere invariato il numero di giri originario premere il tasto "SET".</p>
---	--

	<p><b>Avviso:</b> Durante la modalità di aspirazione il numero di giri non può essere cambiato. L'aspirazione può essere interrotta se si preme e si rilascia contemporaneamente due tasti dei giri fissi "1", "2" o "3".</p>
---	---

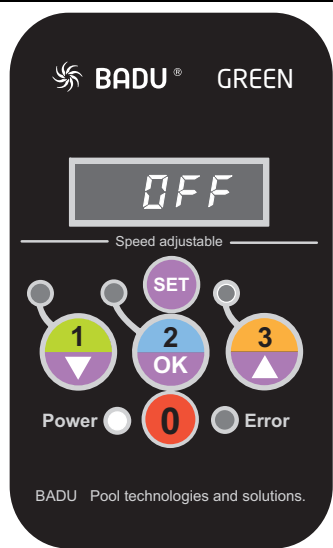

### Impostazione dei parametri di aspirazione:

Per programmare il tempo di aspirazione è necessario arrestare il motore (tasto "0"). Poi ripremere il tasto "SET" per almeno 3 secondi finché l'indicazione del numero di giri sul display non inizia a lampeggiare. Ora si può impostare il numero di giri con cui il motore deve funzionare durante il tempo di aspirazione. Con i tasti "▼ ▲" si può modificare il numero di giri e con "OK" può essere salvato. Dopo aver impostato il numero di giri di aspirazione si può impostare anche la durata del tempo di aspirazione. Essa può essere impostata nell'intervallo da 0 (= Off) a 10 minuti.

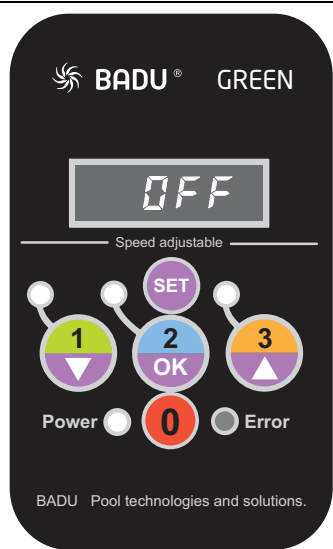

### Reset:

Premendo il tasto "SET" per almeno 15 secondi si può riportare il motore nel suo stato alla consegna. Il motore si arresta ed i tre LED dei numeri di giri fissi si accendono.

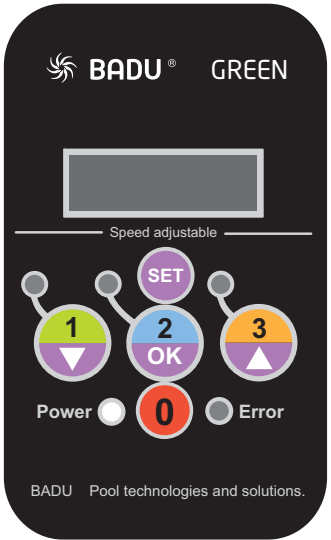
 <p>The image shows a black control panel for a BADU GREEN system. At the top left is the BADU logo and the word 'GREEN'. Below that is a rectangular display screen. Under the screen is the text 'Speed adjustable'. There are three large buttons labeled '1', '2', and '3'. Button '1' is green with a downward arrow, button '2' is blue with 'OK' and a downward arrow, and button '3' is orange with an upward arrow. Above these buttons is a purple 'SET' button. Below them are a white 'Power' button, a red '0' button, and a grey 'Error' button. At the bottom left, it says 'BADU Pool technologies and solutions.' and on the right side, vertically, 'WG27.50.020-P'.</p>	<p>Dopo tre minuti senza alcuna azione, il display della centralina di comando si spegne se una centralina di comando esterna non invia un segnale alla pompa, ad esempio ogni minuto.</p>
<p>In seguito ad una caduta di tensione la pompa si riavvia automaticamente con l'ultimo numero di giri impostato o resta ferma se prima era stata arrestata.</p>	

### **Prospetto dei possibili messaggi di errore e di servizio**

In seguito al verificarsi di un errore, il motore si spegne permanentemente. Eccezione: "Sottotensione". In questo caso il motore si riaccende automaticamente se la tensione resta maggiore di 209 V per almeno 6 secondi.

Se si verifica un errore, l'impianto deve essere scollegato dalla tensione di alimentazione. Vedere il capitolo 2.2 delle istruzioni di funzionamento originali "Pompe aspirazione normale e autoadescanti, con e senza campana – esecuzione (AK)".

<b>Guasto frequenza di lampeg- gio LED rosso - Error</b>	<b>Possibile causa</b>	<b>Rimedio</b>
1	Guasto microprocessore	→ Il microprocessore si riavvia
2	Sottotensione	→ Tensione di alimen- tazione < 180 V AC → La centralina di comando si attiva automaticamente se la tensione resta maggiore di 209 V per più di 6 secondi
3	Temperatura eccessiva / insufficiente	→ Temperatura eccessiva > 100 °C → Temperatura insufficiente < -20 °C
4	Disinserzione per sovracorrente	→ Intensità di corrente eccessiva → Intervento dell'interruttore di massima corrente interno
5	Sovratensione	→ Tensione di alimentazione > 269 V AC
6	Albero bloccato	→ Carico eccessivo sull'albero oppure → motore bloccato
7	Autotest	→ Uno o più autotest non riusciti
8	Errore del motore	→ Una o più fasi non collegate

I seguenti elenchi riguardano i documenti di riferimento!

## 8.1 Smontaggio e montaggio del coperchio/cestello

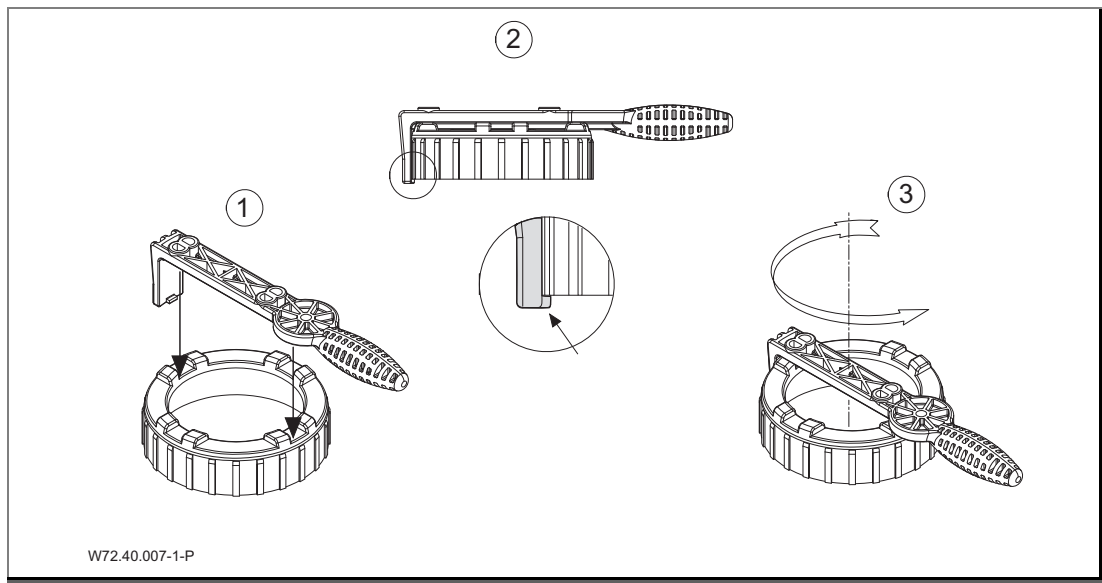

## ES Ficha técnica de la bomba

### Documentos incluidos

Es esta hoja datos de la bomba se incluyen las instrucciones originales para bombas de "aspiración normal y bombas auto-aspirantes con/sin la versión (AK)". Usted debe facilitar el libre acceso para el personal de operación y mantenimiento.

## BADU<sup>®</sup> Eco Touch-Pro II

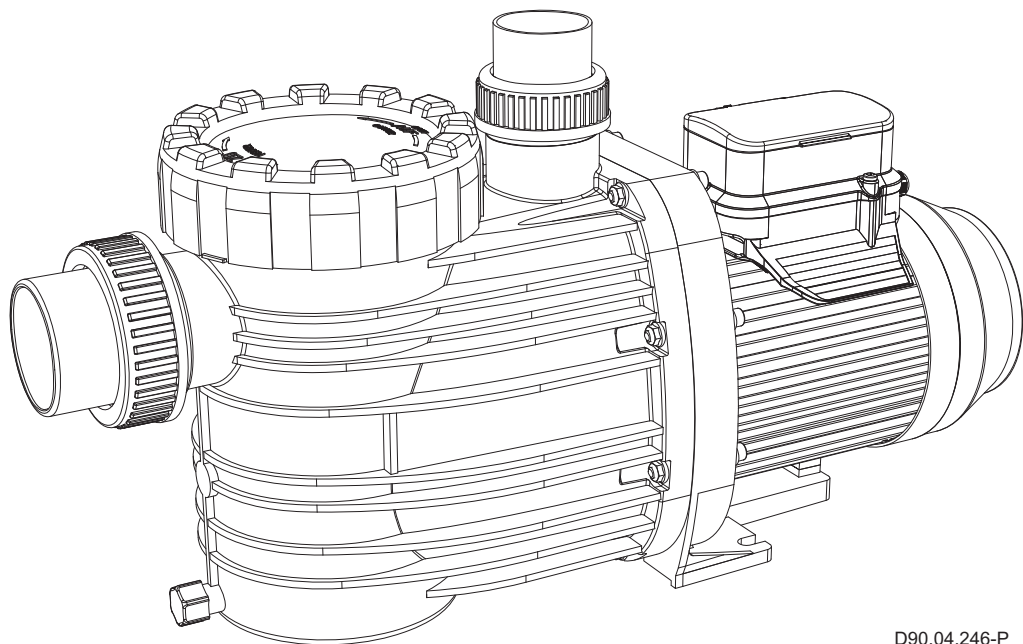

D90.04.246-P

<b>Glosario</b>	
TD	Datos técnicos
Sa	Conexión por aspiración
Da	Conexión por presión
d-Saug	Diámetro recomendado de la conexión por aspiración a 5 m
d-Druck	Diámetro recomendado de la conexión por presión a 5 m
max. L	Maxima largo de la bomba
P <sub>1</sub>	Potencia absorbida
P <sub>2</sub>	Potencia disipada
I	Corriente nominal
Lpa (1 m)	Nivel de presión acústica a un metro de distancia. Mido según norma DIN 45635
Lwa	Potencia acústica
m	Peso
WSK	Protector térmico integrado en la bobina del motor
PTC	Termistor PTC
H <sub>max.</sub>	Altura máxima de presión
SP	Auto-aspirante
Hs; Hz	Altura geodésica sobre el nivel del agua y la bomba
Hs	Aspiración total
Hz	Elevación total en la aspiración
IP	Protección del motor
W-KI	Aislamiento tipo
n	Velocidad de giro
P-GHI	2,5 bar presión interne máxima de carcasa/presión máxima del sistema
T	Temperature del agua
●	Si
○	No
T/°C	Explicación de la temperatura del agua 40 °C (60 °C): 40 °C = vale para temperaturas máximas conforme a las normas GS. (60 °C) = La bomba puede funcionar para una temperatura del agua de 60 °C
1~/3~	Apropiado para un servicio continuo a 1~ 220 - 240 V ± 5% 3~ Y/Δ 380 - 420 V/220 - 240 V ± 5% 3~ Y/Δ 660 - 725 V/380 - 420 V ± 5%  Apropiado para una tensión según la normas DIN IEC 60038; DIN EN 60034

Para tensión especial y/o versión en 60 Hz, el rendimiento se puede encontrar en la placa de la bomba. Para algunos modelos especiales de bombas o motores la norma GS no está disponible – la norma GS debe figurar en la placa de identificación de la bomba.

La bomba tiene un motor de imán permanente y está protegida electrónicamente contra sobrecarga.

### Conexión de contactos de conmutación externos

Para el mando externo la bomba tiene un cable de 5 hilos con cabos abiertos. Asignación de los cables a las velocidades de giro individuales de la siguiente manera:

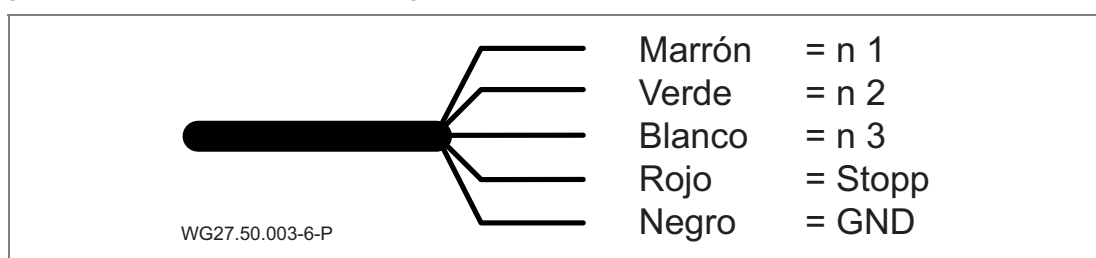

**Los cables se tienen que conectar sin potencial. Conectar sólo individualmente los contactos, de lo contrario no se efectúa la activación de la velocidad de giro deseada.**

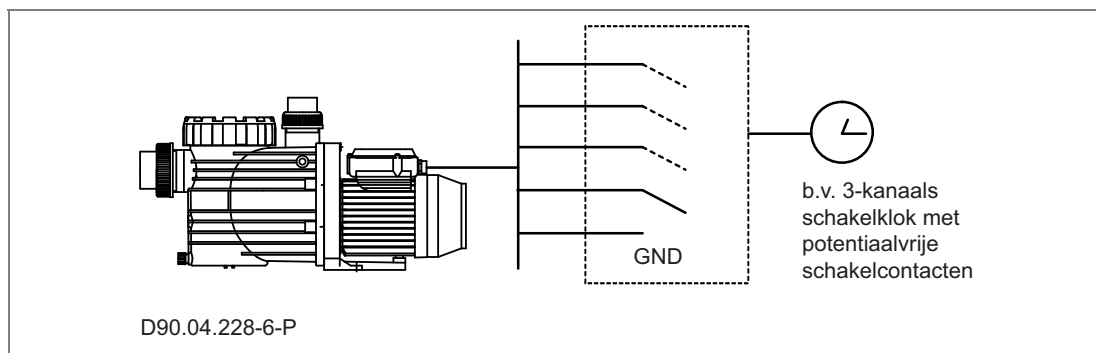

### AVISO

Poner en marcha la velocidad del motor mediante botón pulsador o contactos de conmutación externos. De esta manera se activan los contactos de conmutación y la velocidad de giro asignada.

Arranca la bomba cuando está parada, a continuación la pone en marcha en el modo de aspiración.

Durante el funcionamiento las velocidades fijas se aplican directamente, sin tiempo de aspiración.

Si el mando externo no se necesita, deben aislarse los cabos de cable.

## AVISO

Se recomienda la instalación de un controlador de flujo en la circulación de la bomba para que puedan mostrarse los posibles mensajes de error. Esto permite que se pueda evitar una interrupción más prolongada del ciclo del agua de baño.

### Ajuste previo:

Velocidad:	1 = 2000 min <sup>-1</sup> 2 = 2400 min <sup>-1</sup> 3 = 2830 min <sup>-1</sup>
Velocidad de aspiración:	= 2830 min <sup>-1</sup>
Tiempo de aspiración:	= 5 minutos
Velocidades ajustables:	1000 - 2830 min <sup>-1</sup> (en pasos de 50 min <sup>-1</sup> )
Tiempo de aspiración ajustable:	0 - 10 min. (en pasos de 1 min)

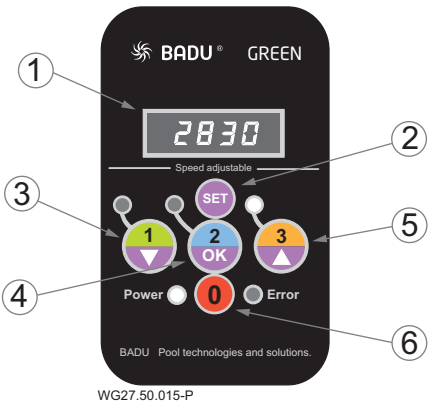

El controlador de velocidad BADU GREEN (WG27.50.015-P) tiene un display de LED que muestra la velocidad actual de 2830 min<sup>-1</sup>. El panel de control incluye un botón "SET" (2), tres botones de selección de velocidad (1/▼, 2/OK, 3/▲) (3, 5) y un botón "0" (6). También hay botones para "Power" (4) y "Error".

### Interfaz de usuario:

- (1) **Display de LED:** indica la actual velocidad de giro del motor.
- (2) **Tecla "SET":** para llegar al modo de programación o para reset del mando.
- (3) **Tecla "1/▼":** para seleccionar la velocidad de giro fija / para cambiar en el modo de programación.
- (4) **Tecla "2/OK":** para seleccionar la velocidad de giro fija / para el almacenamiento en el modo de programación.
- (5) **Tecla "3/▲":** para seleccionar la velocidad de giro fija / para cambiar en el modo de programación.
- (6) **Tecla "0":** para detener el motor.

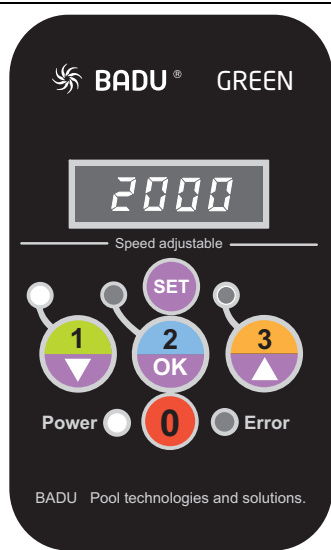

### Manejo:

Pulsar la tecla "1", "2" - o - "3", para seleccionar la velocidad de giro fija preconfigurada.

Arranca la bomba cuando está parada, a continuación la pone en marcha en el modo de aspiración.

Mientras la bomba está en la fase de aspiración, parpadea el LED de la velocidad seleccionada.

Durante el funcionamiento las velocidades fijas se aplican directamente, sin tiempo de aspiración.

Apretando la tecla "0" se detiene el motor. El LED "Power" parpadea y el display indica "OFF".



**Nota:** ¡Cuando se utiliza el bomba con un mando externo, al programar las velocidades de giro y el tiempo de aspiración se debe interrumpir la conexión al mando externo, o aislarlos de la tensión de red!

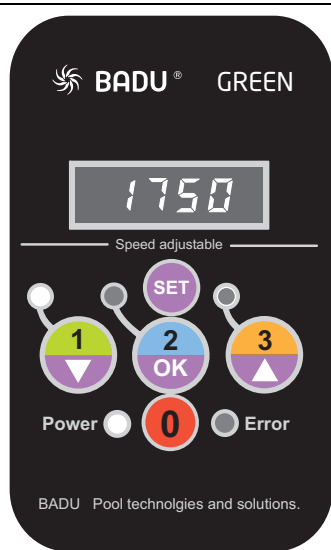

### Ajuste de las velocidades de giro fijas:

Pulsar la tecla de la velocidad de giro fija que debe modificarse, y mantener pulsada la tecla "SET" mín. 3 segundos, hasta que la indicación de velocidad de giro en el display comienza a parpadear. Ahora puede modificarse la velocidad de giro con las teclas "▼ ▲". Confirmar el almacenamiento con "OK". Pulsar la tecla "SET" para interrumpir y mantener la velocidad de giro original.

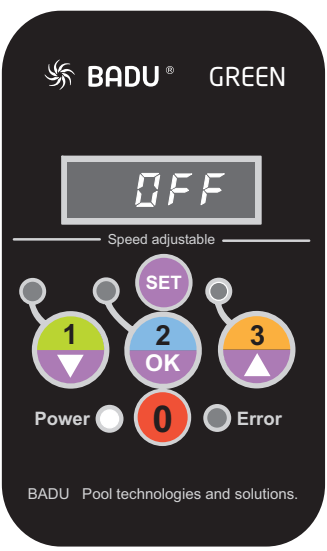

**Nota:** Durante la fase de aspiración, la velocidad no se puede cambiar. Simultáneamente presione y suelte las dos teclas de velocidad fija "1", "2" y/o "3" para que la aspiración pueda interrumpirse.

 <p>WG27.50.018-P</p>	<p><b>Ajuste de los parámetros de aspiración:</b></p> <p>Para programar el tiempo de aspiración debe estar parado el motor (Tecla "0"). Luego pulsar otra vez la tecla "SET" durante mín. 3 segundos, hasta que la indicación de velocidad de giro en el display comienza a parpadear. Ahora puede ajustarse la velocidad de giro con la que el motor funcionará durante el tiempo de aspiración. Con las teclas "▼ ▲" puede modificarse y con "OK" almacenarse la velocidad de giro. Después que se ha ajustado la velocidad de aspiración, puede determinarse la duración del tiempo de aspiración. Ésta puede ajustarse de 0 (= Off) a 10 minutos.</p>
--	---

 <p>WG27.50.019-P</p>	<p><b>Restaurar / Reset:</b></p> <p>El motor puede asignarse de nuevo al estado de suministro pulsando la tecla "SET" durante mín. 15 segundos. El motor se detiene y los tres LEDs de velocidad de giro fija se iluminan.</p>
---	--

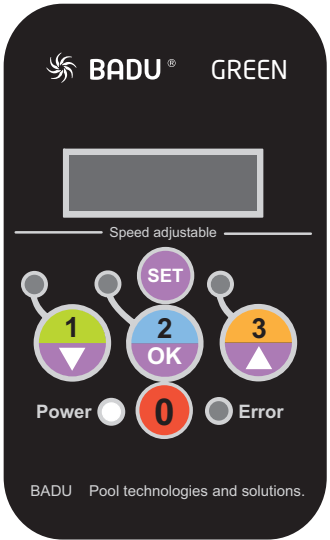
	<p>El display del mando se apaga después de tres minutos sin acción, excepto un mando externo envía p.ej. cada minuto una señal a la bomba.</p>
<p>La bomba arranca automáticamente después de un corte de corriente de nuevo con la velocidad de giro últimamente ajustada, o permanece parada si antes se detuvo.</p>	

### Presentación de posibles avisos de funcionamiento y mensajes de error

Si se produjo un fallo, el motor se desconecta de forma permanente. Fallo excepcional: "Tensión insuficiente". En este caso, el motor se conecta automáticamente de nuevo cuando la tensión sobrepasa 209 V durante al menos 6 segundos.

Si se produce un fallo, la instalación se tiene que desconectar de la alimentación eléctrica. Ver capítulo 2.2 de las instrucciones originales para bombas de "Aspiración normal y bombas auto-aspirantes con/sin la versión (AK)".

<b>LED de Error rojo, parpadeos por fallo</b>	<b>Causa posible</b>	<b>Remedio</b>
1	Fallo de microprocesador	→ El microprocesador vuelve a iniciar
2	Tensión insuficiente	→ Alimentación eléctrica < 180 V CA → El mando se activa automáticamente cuando la tensión sobrepasa 209 V durante más de 6 segundos
3	Temperatura demasiado alta / demasiado baja	→ Temperatura demasiado alta > 100 °C → Temperatura demasiado baja < -20 °C
4	Desconexión de corriente excesiva	→ Corriente demasiado alta → Interruptor protector interno de sobretensión conectado
5	Sobretensión	→ Alimentación eléctrica > 269 V CA
6	Eje bloqueado	→ Carga en el eje demasiado alta o → motor parado
7	Autoprueba	→ Una o más autopruebas no tienen éxito
8	Fallo de motor	→ Una o más fases no están conectadas

Las siguientes enumeraciones se refieren a los documentos convalidados!

## 8.1 Tapa/montaje o desmontaje de los prefiltros de aspiración

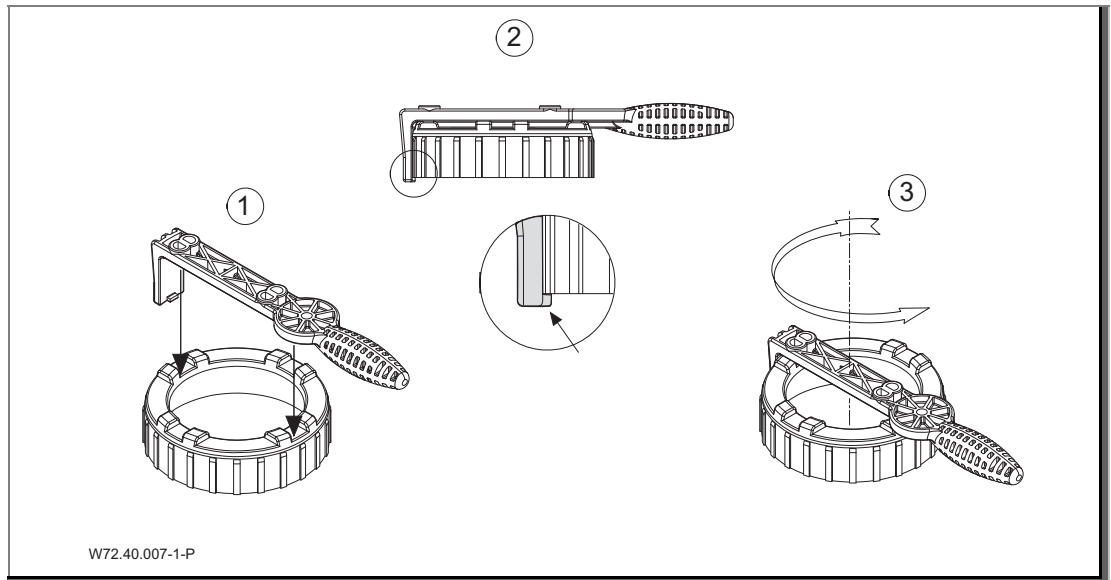



---

## EG-Konformitätserklärung

EC declaration of conformity | Déclaration CE de conformité | EG-verklaring van overeenstemming | Dichiarazione CE di conformità | Declaración de conformidad

### Hiermit erklären wir, dass das Pumpenaggregat/Maschine

Hereby we declare that the pump unit | Par la présente, nous déclarons que l'agrégat moteur-pompe | Hiermee verklaren wij, dat het pompaggregat | Con la presente si dichiara, che la il gruppo pompa/la macchina | Por la presente declaramos que la unidad de bomba

### Baureihe

Series | Série | Serie | Serie | Serie

### BADU Eco Touch-Pro II

### folgenden einschlägigen Bestimmungen entspricht:

is in accordance with the following standards: | correspond aux dispositions pertinentes suivantes: | in de door ons geleverde uitvoering voldoet aan de eisen van de in het vervolg genoemde bepalingen: | è conforme alle sequenti disposizioni pertinenti: | cumple las siguientes disposiciones pertinentes:

### EG-Maschinenrichtlinie 2006/42/EG

EC-Machine directive 2006/42/EC | CE-Directives européennes 2006/42/CE | EG-Machinerichtlijn 2006/42/EG | CE-Direttiva Macchine 2006/42/CE | directiva europea de maquinaria 2006/42/CE

### EMV-Richtlinie 2014/30/EU

EMC-Machine directive 2014/30/EU | Directives CE sur la compatibilité électromagnétique 2014/30/UE | Richtlijn 2014/30/EU | Direttiva di compatibilità elettromagnetica 2014/30/EU | directiva 2014/30/UE

### EG-Richtlinie 2002/96/EG (WEEE)

Directive 2002/96/EC (WEEE) | Directive CE 2002/96 (DEEE) | EG-Richtlijn 2002/96/EG (WEEE) | Direttiva 2002/96/CE (WEEE) | CE-Directiva 2002/96/EG (tratamiento de residuos de componentes de aparatos eléctricos y electrónicos en desuso)

### EG-Richtlinie 2011/65/EG (RoHS)

Directive 2011/65/EC (RoHS) | Directive CE 2011/65 (RoHS) | EG-Richtlijn 2011/65/EG (RoHS) | Direttiva 2011/65/CE (RoHS) | CE-Directiva 2011/65/EG (limitación de utilización de determinados productos peligrosos en aparatos eléctricos y electrónicos)

### Ökodesign-Richtlinie 2009/125/EG

Ecodesign Directive 2009/125/EC | Directive d'écoconception 2009/125/CE | Ecodesign-richtlijn 2009/125/EG | Direttiva sulla progettazione ecocompatibile 2009/125/CE | Directiva 2009/125/CE  
Ecodiseño

### Angewendete harmonisierte Normen, insbesondere

According to the provisions of the harmonized standard for pumps in particular | Normes harmonisées appliquées, notamment | Gebruikte geharmoniseerde normen, in het bijzonder | Norme armonizzate applicate in particolare | Normas armonizadas aplicadas, especialmente

EN 60335-1:2012

EN 60335-2-41:2003

EN 61800-3:2004

EN 61000-4-2/3/5/6/11/13/28

EN 61000-3-2:2006

---



**i.V. Sebastian Watolla**

Technischer Leiter und Dokumentations-  
bevollmächtigter | Technical director and  
authorised representative | Directeur technique et  
responsable des documentations | Technisch  
directeur en documentatie gemachtigde | Direttore  
tecnico e autorizzato per la documentazione |  
Director técnico y documentación autorizada

91233 Neunkirchen am Sand, 16.06.2017



**Armin Herger**

Geschäftsführer | Managing Director |  
Gérant | Bedrijfsleider |  
Amministratore | Gerente

**SPECK X**  
pumpen

SPECK Pumpen Verkaufsgesellschaft GmbH  
Hauptstraße 3, 91233 Neunkirchen am Sand, Germany